

## OVERALL DIMENSIONS

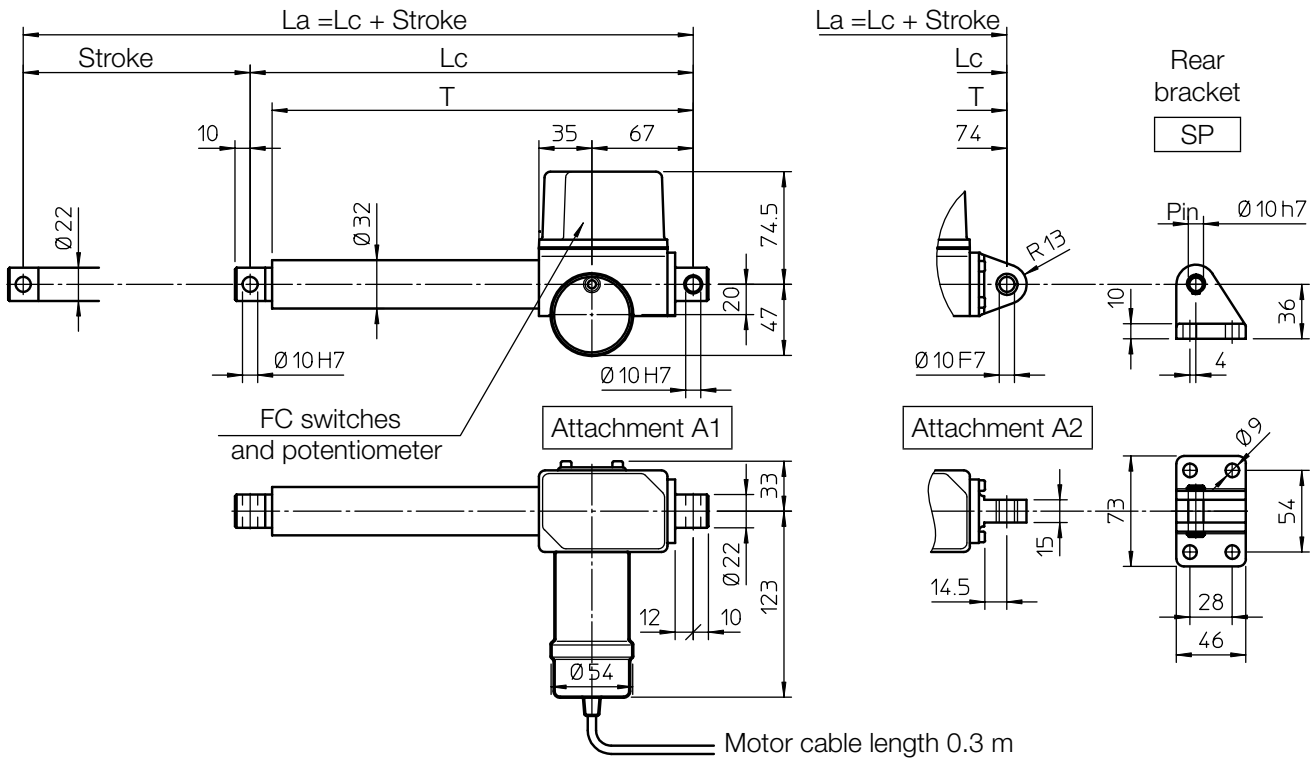

Length	Actuator with Attachment A1	Actuator with Attachment A2
Lc [mm]	142 + Stroke	150 + Stroke
T [mm]	129 + Stroke	136 + Stroke

## PERFORMANCES AND FEATURES

- Pull-Push load up to 2 000 N
  - Linear speed up to 48 mm/s (DC motor)
  - Linear speed up to 30 mm/s (AC motor)
  - Standard stroke lengths: 100, 150, 200, 250, 300 mm (for different / longer stroke lengths please contact us)
  - Aluminium alloy housing and rear attachment
  - Anodized aluminium outer tube
  - Anodized aluminium push rod – tolerance h8
  - Rear attachment:
    - A1 zinc-plated steel
    - A2 aluminium alloy with bronze bush
  - Stainless steel AISI 303 front attachment
  - Motors: (motor features details on page 69 and 70)
    - 12 or 24 V DC motor with permanent magnets
    - AC 3-phase or 1-phase motor
  - Duty cycle with max load:
    - DC motor max.15% over 10 min at (-10 ... +40) °C
    - AC motor max.30% over 10 min at (-10 ... +40) °C
  - Standard protection:
    - with DC motor IP65
- Test IP6X according to EN 60529 §12 §13.4-13.6  
Test IPX5 according to EN 60529 §14.2.5 (tests made with not running actuator)  
- with AC motor IP55

- Standard motor mounting position as per sketch (right-hand, code RH)
- Long-life lubrication, maintenance free

## ACCESSORIES

- Stainless steel push rod (code SS)
- Rear bracket (code SP) with rear attachment A2
- Adjustable electric stroke end switches (code FC2)
- Adjustable electric stroke end switches, switching off the motor (not available with AC 3-phase motor) (code FC2X)
- Extra switch for intermediate position (code FC)
- Rotative potentiometer 5kOhm for positioning control (code POR5K)

NOTE: Extra limit switch and rotative potentiometer cannot be selected together

## OPTIONS

- Motor mounting position on opposite side (left-hand, code LH)
- Fixing attachment turned at 90° (code RPT 90)

### PERFORMANCES with AC 3-phase 50 Hz 230/400 V or 1-phase 50 Hz 230 V motor

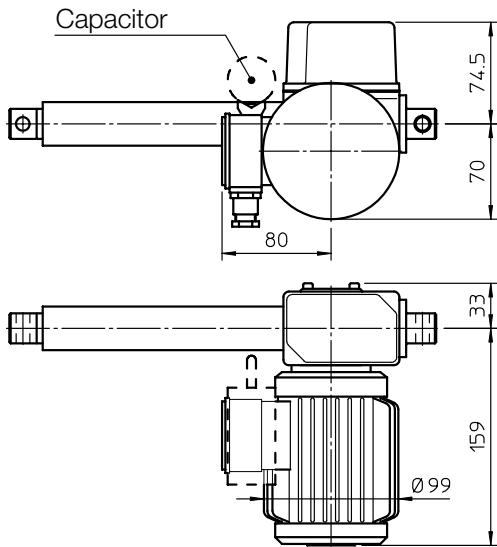

1-start acme screw Tr 13.5×3		
0.06 kW - 2 pole motor		
RATIO	LOAD [N]	SPEED [mm/s]
RN1	1500	11
RL1	2000	5.5

2-starts acme screw Tr 14×8 (P4)		
0.06 kW - 2 pole motor		
RATIO	LOAD [N]	SPEED [mm/s]
RN2	1000	30
RL2	1100	15

### PERFORMANCES with 24 V DC motor

(Performances with 12 V DC motor: same load, linear speed 10 % less, electrical consumption 2 times more)

#### 1-start acme screw Tr 13.5×3

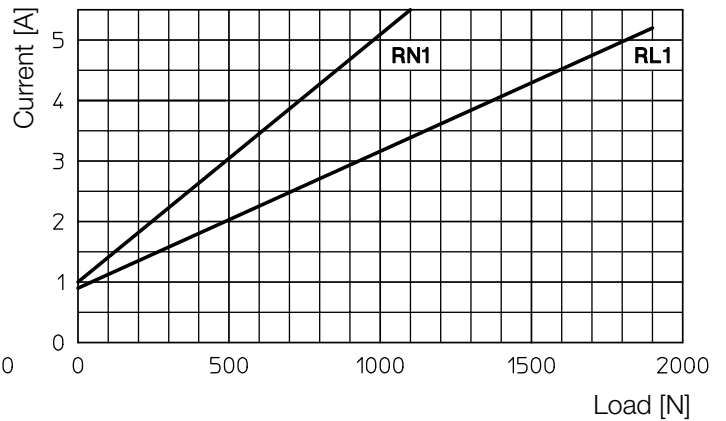
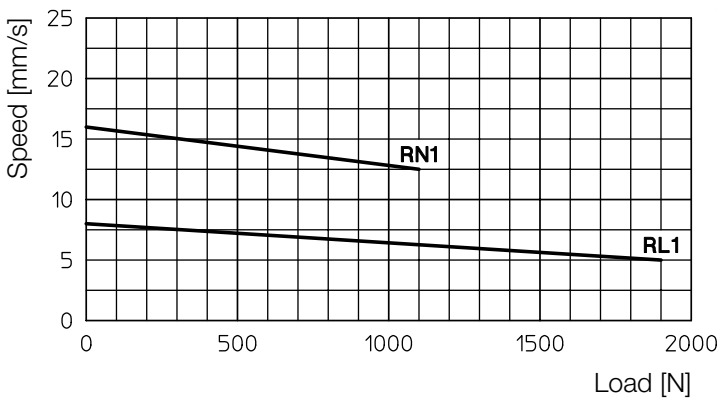

#### 2-starts acme screw Tr 14×8 (P4)

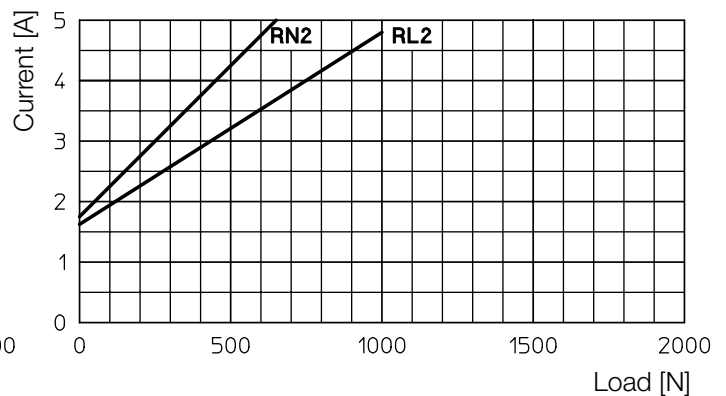
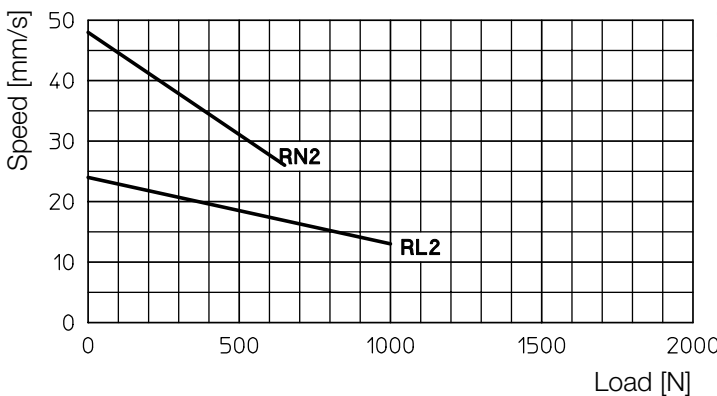

### Self-locking conditions

Information about statically self-locking conditions with pull or push load on page 68.

### ORDERING CODE EXAMPLE

CLA 20	RL1	C200	CC 24 V	FC2	POR 5K			
Actuator	Selected ratio	Required stroke	Motor	Stroke end switches	Accessories		Options	

## 12. GENERAL FEATURES

### 12.3 DC MOTORS

#### Motors with interchangeable brushes (actuators ATL 10, UAL 0, BSA 10, BSA 11, UBA 0, CLB 25, CLB 27)

Permanent magnet DC motors, without fan, available with or without brake.

Long-life brushes, easy to replace.

Bipolar power supply cable 2 x 1 mm<sup>2</sup>, 1.5 m length. Motor weight: 1.3 kg.

Output power	70 W		Rated speed	3000 rpm	
Rated current	3.7 A (24 V)	8.4 A (12 V)	Rated torque	0.22 Nm	
Peak current	18 A (24 V)	30 A (12 V)	Peak torque	1.1 Nm	
Resistance	0.85 Ohm (24 V)	0.23 Ohm (12 V)	Inductance	1.34 mH (24 V)	0.36 mH (12 V)
Protection class	IP 54		Insulation class	F	

MOTOR BRAKE: Normally closed holding brake activated by DC electromagnet available on request.

Brake separately wired with bipolar cable 2 x 1 mm<sup>2</sup>, 1 m length.

Motor with brake total weight: 1.8 kg.

Power supply: 0.4 A a 24 V; 0.85 A a 12 V	Braking torque: 0.5 Nm
---	------------------------

**WARNING! The motor brake is normally closed; to open it, a constant rated voltage power supply is required. With lower voltage, the brake does not open.**

#### Motors with non-interchangeable brushes (linear actuators LMR, ATL, CLA, LMP, LMI Series)

Permanent magnet DC motors, without fan.

The brake is not available; the brushes are not interchangeable.

Standard motors winding has insulation class B.

These motors have open enclosures: the actuator is fitted with proper motor outer protections which allow to reach motor Protection Class IP 65.

The performance diagrams concerning actuators with DC motor stated in this catalogue, show the input power variation depending on the load variation.

This allows to select power supply / drivers properly.

#### Motor wires connection – Actuator push rod travelling direction

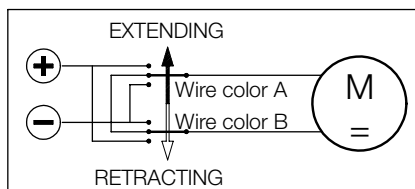

Actuator with DC motor, RIGHT-HAND mounting	LMR 01	LMR 03	ATL 02	ATL 05	ATL 08	ATL 12	CLA 20	CLA 25
Wire color A	red	red	brown	brown	brown	red	brown	brown
Wire color B	black	black	blue	blue	blue	blue	blue	blue

Actuator with DC motor, LEFT-HAND mounting	LMR 01	LMR 03	ATL 02	ATL 05	ATL 08	ATL 12	CLA 20	CLA 25
Wire color A	red	red	blue	blue	blue	blue	blue	blue
Wire color B	black	brown	brown	brown	brown	red	brown	brown

12.4 AC MOTOR							
Actuator	Motor	Power kW	N° of poles	Input voltage Vca	Frequency Hz	Rated current A	Capacitor uF
ATL 02	AC 3-phase	0.06	2	230/400	50	0,7-0,4	-
	AC 1-phase	0.06		230		0.68	5
ATL 10	AC 3-phase	0.12	2	230/400	50	0,81-0,46	-
		0.09	4			0,8-0,45	-
	AC 1-phase	0.12	2	230		2.6	12.5
		0.09	4			1.6	12.5
ATL 12	AC 3-phase	0.25	2	230/400	50	1,3-0,75	-
		0.18	4			1,1-0,66	-
	AC 1-phase	0.25	2	230		2.1	20
		0.18	4			1.9	16
CLA 20	AC 3-phase	0.06	2	230/400	50	0,7-0,4	-
	AC 1-phase	0.06		230		0.68	5
CLA 25 CLA 25S CLA 25M	AC 3-phase	0.12	2	230/400	50	0,81-0,46	-
		0.09	4			0,8-0,45	-
	AC 1-phase	0.12	2	230		2.6	12.5
		0.09	4			1.6	12.5
CLA 28 CLA 28 T	AC 3-phase	0.06	2	230/400	50	0,7-0,4	-
	AC 1-phase	0.06		230		0.68	5
BSA 10 BSA 11	AC 3-phase	0.12	2	230/400	50	0,81-0,46	-
		0.09	4			0,8-0,45	-
	AC 1-phase	0.12	2	230		2.6	12.5
		0.09	4			1.6	12.5
BSA 12	AC 3-phase	0.25	2	230/400	50	1,3-0,75	-
		0.18	4			1,17-0,66	-
	AC 1-phase	0.25	2	230		2.1	20
		0.18	4			1.9	16
CLB 25 CLB 27	AC 3-phase	0.12	2	230/400	50	0,81-0,46	-
		0.09	4			0,8-0,45	-
	AC 1-phase	0.12	2	230		2.6	12.5
		0.09	4			1.6	12.5

12.4 AC MOTOR							
Insulation class (1)	Motor protection class (1)	Fan	Brake	Brake coil power supply (2) (3)	Brake rated current A	Braking torque Nm	Brake protection class
F	IP 55	Not available	Not available	-	-	-	-
F	IP 55	Standard	On request	DC powered by rectifier	0.05	1.7	IP 44
F	IP 55	Standard	On request	DC powered by rectifier	0.09	4	IP 44
F	IP 55	Not available	Not available	-	-	-	-
F	IP 55	Standard	On request	DC powered by rectifier	0.05	1.7	IP 44
F	IP 55	Standard	Not available	-	-	-	-
F	IP 55	Standard	On request	DC powered by rectifier	0.05	1.7	IP 44
F	IP 55	Standard	On request	DC powered by rectifier	0.09	4	IP 44
F	IP 55	Standard	On request	DC powered by rectifier	0.05	1.7	IP 44

(1) Higher insulation and protection classes available on request.

(2) Normally closed activated by DC electromagnet.  
The electromagnet is powered by a 1-phase rectifier fitted in the terminal box.

(3) Motors with separately powered brake available on request.  
This solution shall be used for applications with frequency inverter.

## 13.4 Electric cam-operated stroke end switches (linear actuators CLA and CLB Series)

Code **FC2**: two electric cam-operated switches, wired on contact NC (to be connected into the external control circuit). On request, the switches can be wired on the contact NO or on the switch-over contact CS. (For available configurations please contact our Technical Dpt).

Code **FC2X**: two electric cam-operated switches, internally wired between power supply and electric motor, in order to switch off the power supply directly, without relays. Available for actuators with Dc or AC 1-phase motor.

Code **FC2 + FC** or **FC2X + FC**: Stroke end switches FC2 or FC2X with a third switch for any intermediate position. The third switch can be wired on contact NC or NO on request. (For different configurations please contact our Technical Dpt).

SWITCH RATED VALUES		
Voltage	Max current	
	Resistive load	Inductive load
250 Vac	21 A	12 A
30 Vdc	14 A	12 A
125 Vdc	0.8 A	0.6 A

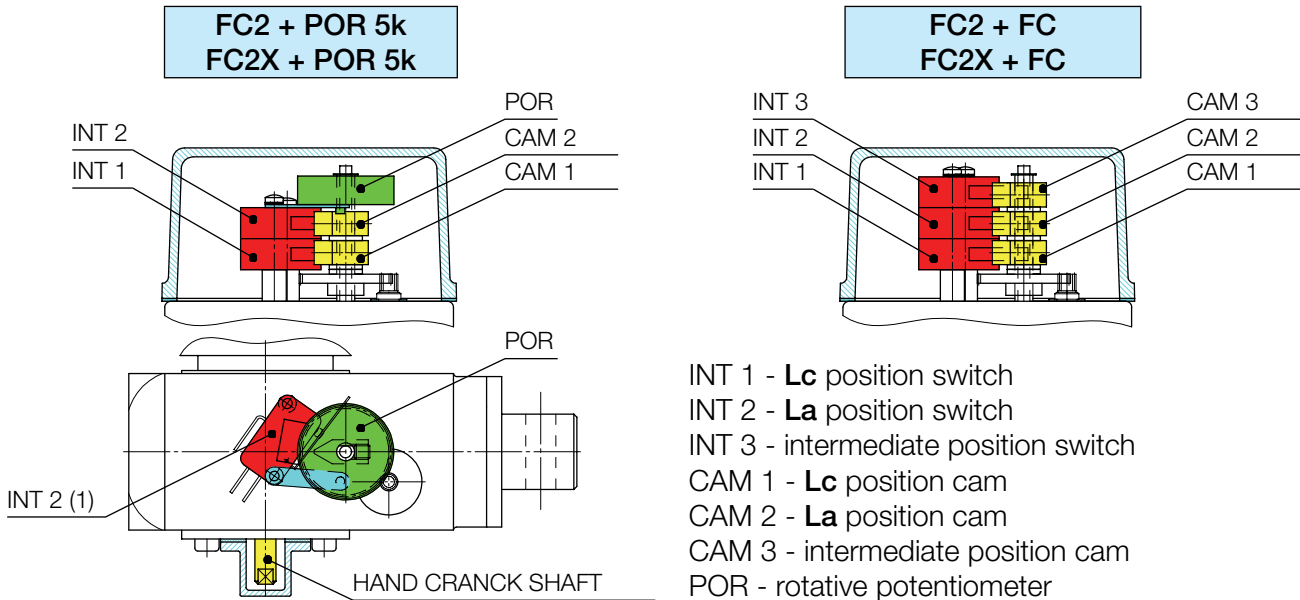

**Lc** = actuator retracted length, **La = Lc + Stroke** – actuator extended length

## 13.4 Rotative potentiometer for positioning control (linear actuators CLA and CLB Series)

Code **POR 5k**: rotative potentiometer, single turn (340°), 5 kOhm ± 20 %, linearity ± 2 %

The rotative potentiometer is an absolute transducer, whose output signal is proportional to the current position of the actuator push rod. Analogic output signal.

Standard cable: 4 x 0.25 mm<sup>2</sup> + shield, 1.5 m length (for different configurations please contact us).

POR 5k standard wiring diagram:

POR Power supply: 0 V dc

Reference signal: ZERO

Reference signal: RETURN

POR Power supply: + V cc

SHIELD

