



Copley Motion Systems LLC

Selection Guide



Servo Amplifiers • Stepper Amplifiers • Control Software
Linear Motors • Linear Actuators



Table of Contents

Introduction	3
Architecture Flexibility	4
Centralized & Distributed Control	6
The Distributed Control Solution	8
Configuration and Control Software	10
Amplifier Technology.....	12
Digital Servo & Stepper Amplifiers	13
Xenus 100 - 240 VAC Digital CANopen Amplifier for Brushless/Brush Motors	14
Accelnet Digital CANopen Amplifier for Brushless/Brush Motors	15
Stepnet Digital CANopen Amplifier for Stepper Motors	16
Accelus Digital Amplifier for Brushless/Brush Motors	17
Junus Digital Amplifier for Brush Motors	17
Analog Amplifiers	18
7 Series Sinusoidal Analog Amplifiers for Brushless Motors	19
5 Series Trapezoidal Analog Amplifiers for Brushless Motors	20
4 Series Analog Amplifiers for Brush Motors and Voice Coils	21
Custom OEM Solutions	22
Motor Technology	23
ServoTube Linear Actuators and Motor Components	24
ThrustTube Modules and Motor Components	26



Introduction

About Copley Controls Corporation

Copley Controls Corporation delivers high performance motion solutions to a wide range of industries including semiconductor, life sciences, automated assembly, test and measurement and packaging. Headquartered in the US with a division in England, Copley has over 20 years of experience in OEM partnerships. Our global commitment is backed with sales offices and local technical support in the US, Europe and Asia.



Amplifiers and Control Software



From networked servo and stepper amplifiers for distributed control to traditional torque amplifiers, Copley has the solution for your system architecture requirements. Amplifiers are available in a flexible range of packaging options in the 250W - 5kW power range. Copley software tools make distributed control system commissioning fast and simple. Advanced tuning and commutation algorithms, made possible by state-of-the-art DSP technology, maximize motor performance.

Linear Motors and Actuators

Copley Controls is the inventor of the tubular linear motor, setting new standards for performance and ease of mechanical integration. Patented magnetics and integral feedback deliver unprecedented repeatability without the need for a linear encoder – an optimal solution for high dynamic, medium precision applications. Copley also offers a full range of motor components and modules with integrated bearings and linear encoders for high precision applications.

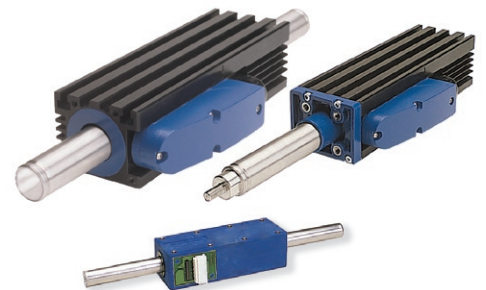

Architecture Flexibility

Whether you use a PC based distributed control architecture, a PLC or a traditional motion controller, Copley Controls has the amplifier to meet your needs.

PC - Distributed Control

With CANopen connectivity, Copley servo and stepper drives deliver all the benefits of distributed control. Copley software tools integrate seamlessly into your Labview, Visual Basic, C++ or CoDeSys (soft PLC) application program. Indexer functionality allows control via an RS232 Ascii interface.

Motion Controller - Centralized Control

A variety of interface options are available for the traditional centralized control architecture. The drives accept digital (PWM) and analog ($\pm 10V$) current and velocity commands. Sinusoidal analog drives also accept commutated UV current commands.

PLC - Distributed and Centralized Control

Copley drives integrate easily into PLC systems via discrete I/O, Ascii commands or traditional drive interfaces. Drives operate as indexers with preprogrammed move sequences or accept step/direction commands and analog torque/velocity commands.

PC - Distributed Control

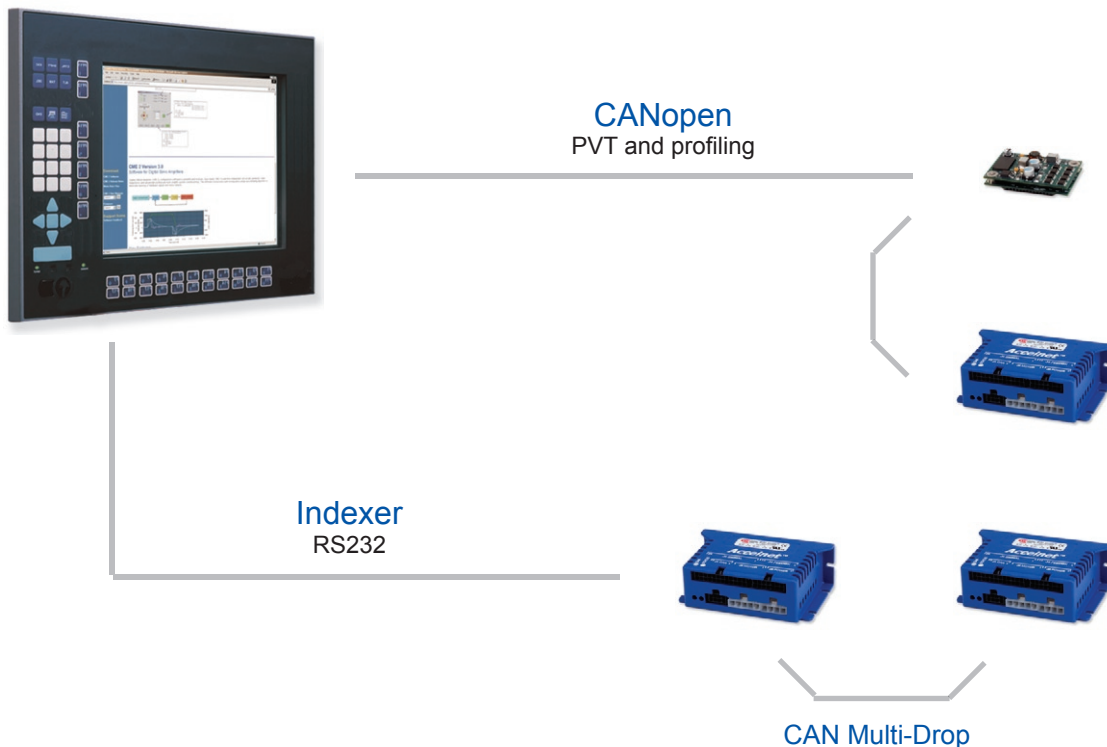

Motion Controller - Centralized Control

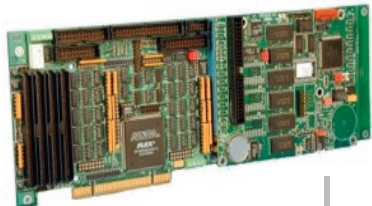

±10V Command
Velocity/Current



PWM Command
Velocity/Current



UV Command
Commutated Current



PLC - Distributed and Centralized Control



Indexer
RS232 or I/O interface



Step/Direction
Interface to stepper modules



±10V Command
Interface to motion modules



Centralized & Distributed Control

The merits of centralized and distributed control are best understood by a review of system task hierarchy. Centralized control typically closes the position and velocity loops in a motion controller. Distributed control moves all servo loops to the drive. Path-planning can also be incorporated in the drive enabling indexer functionality and control via a simple Ascii interface.

Centralized Control Hierarchy

Motion Controller and Torque Mode Drive

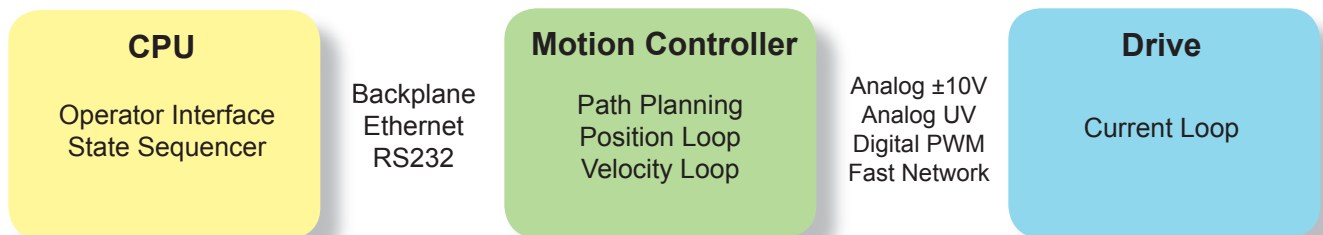

Centralized Control Advantages

- Can be an optimal solution for applications with tightly coupled* axes and high performance line-shafting
- Path planning is offloaded from the CPU
- Motion Card can control entire machine in simple applications

*Axes with servo parameters dynamically dependent on other axes as in high-end robotic applications

Copley Amplifiers for Centralized Control

Accelus	Digital amplifier for brushless and brush motors
Junus	Digital amplifier for brush motors and voice coils
7 Series	Analog sinusoidal amplifiers for brushless motors
5 Series	Analog trapezoidal amplifiers for brushless motors
4 Series	Analog amplifiers for brush motors and voice coils

Distributed Control Hierarchy

PC Based Control - CANopen PVT Mode

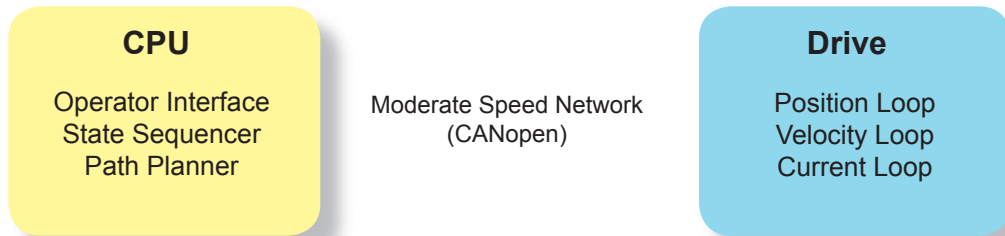

PC/PLC Based Control - CANopen Profile Mode or Indexer



Distributed Control Advantages

- Optimal solution for most applications
- 40-50% cost savings by elimination of Motion Controller and breakout boxes
- Simple cabling for fast installation and high reliability
- Sensitive analog signals or expensive high speed network replaced by rugged, low cost network
- Axis count is easily expanded without requiring additional Motion Controller
- All loops are closed in each drive so servo performance is not degraded as axes are added

Copley Amplifiers for Distributed Control

NOTE:	All distributed control amplifiers have interfaces for centralized control systems
Xenus	100-240 VAC digital amplifier for brushless and brush motors
Accelnet	Digital amplifier for brushless and brush motors
Stepnet	Digital amplifier for stepper motors

The Distributed Control Solution

Copley distributed control software makes system commissioning fast and simple. Engineers with no CANopen experience can get a multi-axis motion application up and running quickly.

Automatic Network Management

The development of low-level code to control a CANopen network of intelligent drives is eliminated. All network management is taken care of automatically by a few simple commands linked into your application program.

Application Program Flexibility

Copley supports two development environments. Copley Motion Libraries (CML) link into a C++ application program. Copley Motion Objects (CMO) are COM objects that can be used by Visual Basic®, .NET®, Labview® or any program supporting the COM object interface.

Control Platform Flexibility

CML delivers optimal flexibility and performance. The application program can run on a PC under Windows and Linux or on an embedded microprocessor with any real-time multi-tasking operating system. CMO provides optimal ease of use for applications running under Windows.

Controller Hardware and Distributed Drives

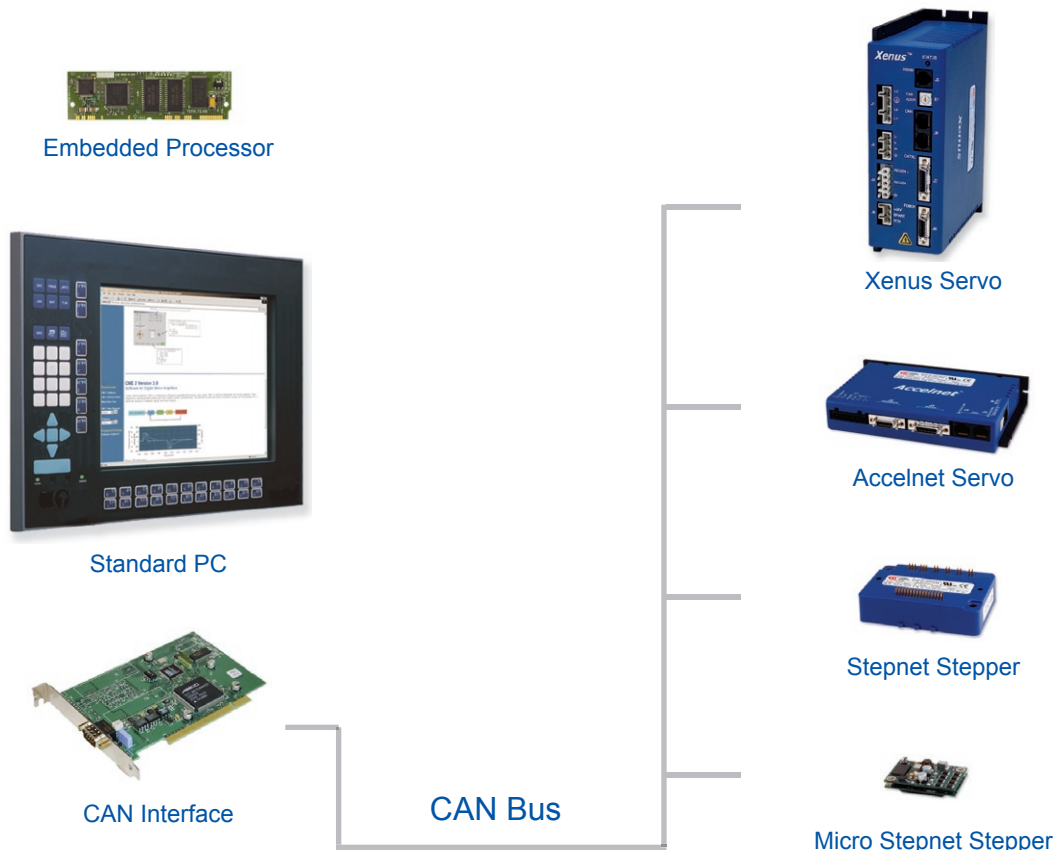

Quickly Create a Powerful Motion Application

Labview Program

Each CMO method appears in a separate function block to perform two relative moves.

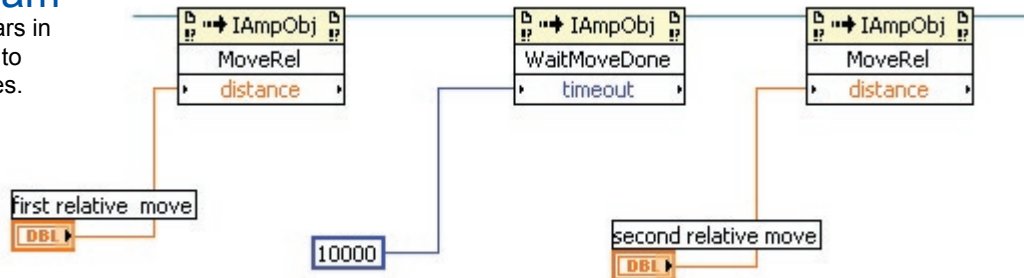

Command Menu

Amplifier properties and methods appear in a drop-down list. Simply scroll and select. CANopen DSP-402 commands include: enable, homing, get/set parameters, point-to-point and coordinated moves.

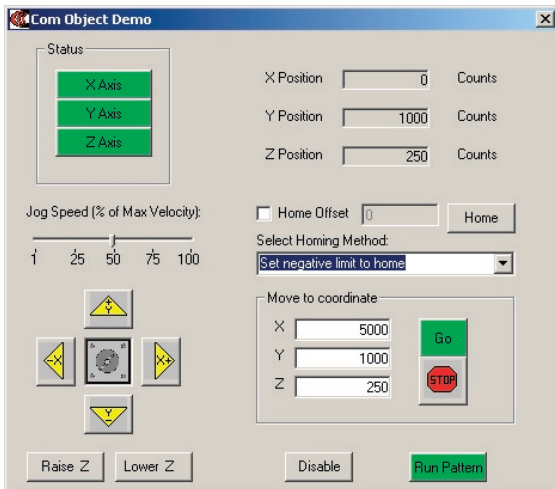
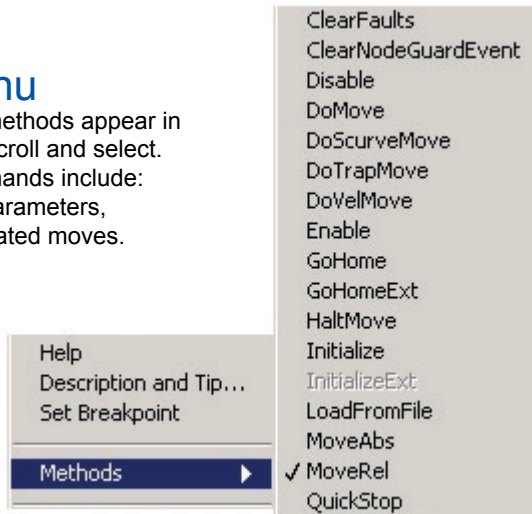

Graphical User Interface

Visual Basic combines seamlessly with CMO for integrated graphical user interface and machine control.



Configuration and Indexing

Java based Copley Motion Explorer (CME 2) configuration and control software is powerful and intuitive. Clear diagnostics and advanced oscilloscope tools simplify system commissioning. Advanced auto-phasing algorithm eliminates rewiring of encoder, Halls and motor. Indexer control program runs as a separate task on Copley Virtual Machine (CVM).

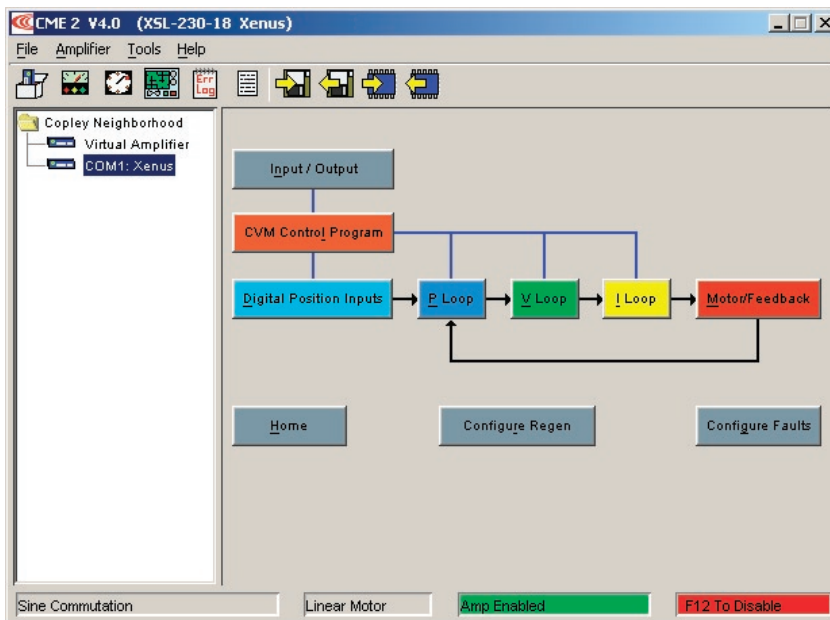

Copley Virtual Machine
Copley Virtual Machine enables control programs to run as independent amplifier tasks. CVM runs in any amplifier mode.

Indexer Program

Define simple indexes, change parameters, handle I/O or create powerful sequences of indexes and commands. Any parameter (e.g. move distance, gain) can be assigned to a register enabling on-the-fly adjustment by an external controller.

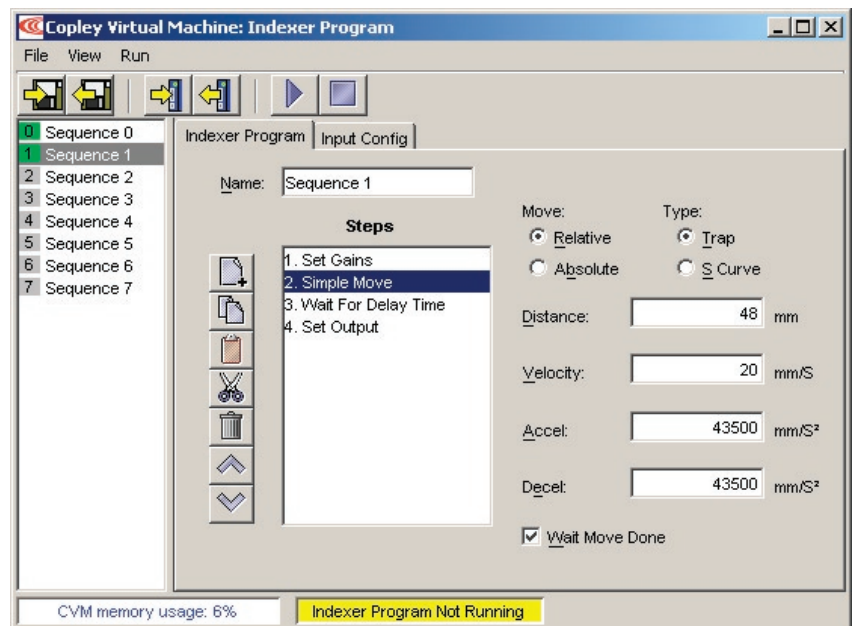

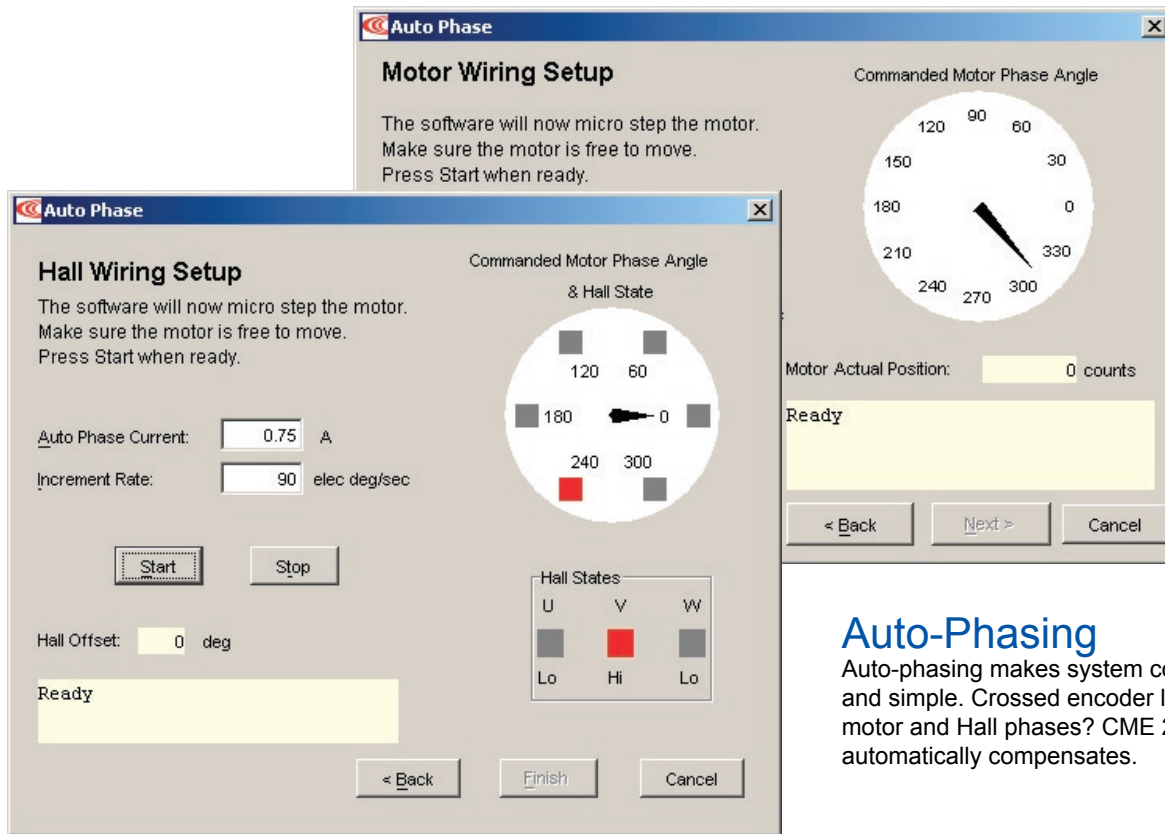

Auto-Phasing

Auto-phasing makes system commissioning fast and simple. Crossed encoder lines or mis-wired motor and Hall phases? CME 2 automatically compensates.

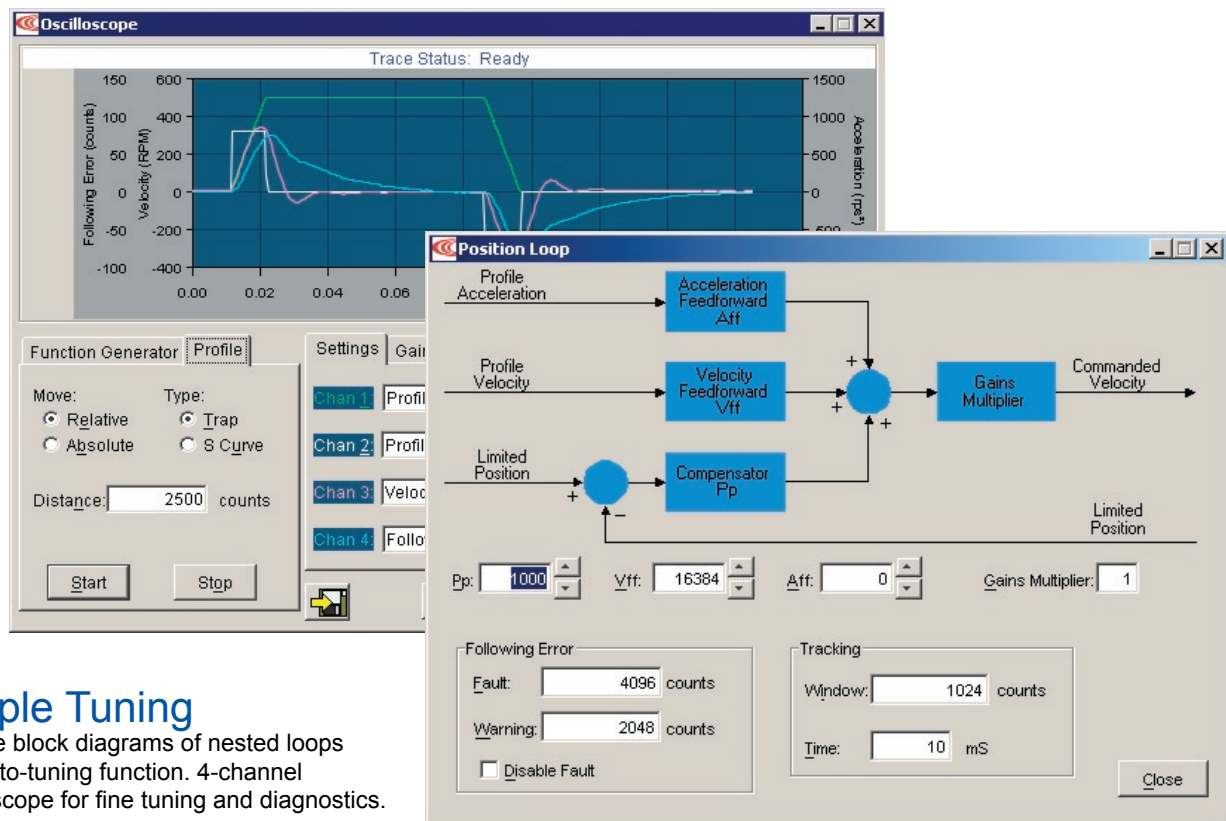

Simple Tuning

Intuitive block diagrams of nested loops with auto-tuning function. 4-channel oscilloscope for fine tuning and diagnostics.

Amplifier Technology

Field Oriented Control

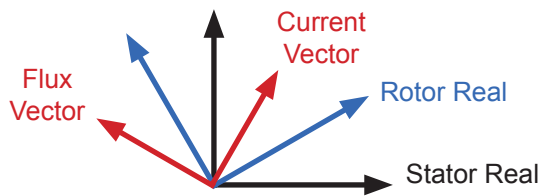

- Ideal orientation of magnetic fields
- Motors run faster and cooler
- Amplifier is more efficient

With over 20 years experience, Copley Controls is a world leader in amplifier design.

State-of-the-art DSP technology enables advanced control algorithms for both servo and stepper motors.

Stepper Technology



- Microstepping
- Servo Mode with encoder feedback
- Electronic damping
- Detent torque compensation
- Trajectory profiling

Servo and PWM Performance

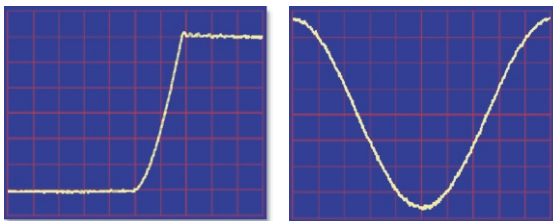

- High bandwidth nested loops
- Zero crossover distortion
- Precision current sensing
- Edge filtering for low emissions
- Dynamic PWM for high efficiency

Patented current sensing and PWM edge filtering deliver optimal performance in precision applications.

Digital Servo & Stepper Amplifiers

Copley offers a complete range of digital amplifiers for brushless, brush and stepper motors. High power density panel-mount and PCB-mount packaging options are available. Operating modes include CANopen distributed drive, indexer and traditional velocity/torque drive. See www.copleycontrols.com for a full range of accessories.



Xenus
Digital CANopen amplifiers
for brushless/brush motors



Accelnet
Digital CANopen amplifiers
for brushless/brush motors



Junus
Digital amplifiers
for brush motors



Stepnet
Digital CANopen amplifiers
for stepper motors



Accelus
Digital amplifiers for
brushless/brush motors

	Xenus	Accelnet	Stepnet	Accelus	Junus
Motor	Brushless/Brush	Brushless/Brush	Stepper	Brushless/Brush	Brush
Input Power	100 - 240 VAC	20 - 180 VDC	20 - 75 VDC	20 - 180 VDC	20 - 180 VDC
Continuous Current	6 - 20 A	1 - 12 A	2 - 5 A	3 - 12 A	5 - 10 A
CANopen	Yes	Yes	Yes	No	No
Indexer	Yes	Yes	Yes	No	No
Step/Direction	Yes	Yes	Yes	Yes	No
PWM velocity/current	Yes	Yes	Yes	Yes	Yes
±10V velocity/current	Yes	Yes	No	Yes	Yes
Feedback	Encoder Analog Encoder Resolver	Encoder Analog Encoder	Encoder	Encoder	Back-Emf

Xenus

100-240 VAC Digital CANopen Amplifier for Brushless/Brush Motors



Xenus Standard

Model	VAC	Ic	Ip
XSL-230-18	100 - 240	6	18
XSL-230-36	100 - 240	12	36
XSL-230-40	100 - 240	20	40



Xenus Resolver

Model	VAC	Ic	Ip
XSL-230-18-R	100 - 240	6	18
XSL-230-36-R	100 - 240	12	36
XSL-230-40-R	100 - 240	20	40

Control Modes

CANopen: PVT, Profile position/velocity/torque, Homing Indexer, Position, Velocity, Torque

Command Interface

CANopen
 Ascii and discrete I/O
 Stepper commands
 ±10V velocity and torque command
 PWM velocity and torque command
 Master encoder (electronic gearing)

Communications

CAN
 RS232

Feedback

Digital quad A/B encoder
 Secondary encoder / emulated encoder out
 Analog sin/cos encoder
 Resolver (-R version)
 Digital Halls

I/O - Digital

12 inputs, 4 outputs

Regen

Internal transistor

Accessories

External regen resistors
 External edge filter

Dimensions

191 x 140 x 64 mm (7.5 x 5.5 x 2.5 in)

Accelnet

Digital CANopen Amplifier for Brushless/Brush Motors



Accelnet Panel

Panel	VDC	Ic	Ip
ACP-055-18	20 - 55	6	18
ACP-090-09	20 - 90	3	9
ACP-090-18	20 - 90	6	18
ACP-090-36	20 - 90	12	36
ACP-180-09	20 - 180	3	9
ACP-180-18	20 - 180	6	18



Accelnet Micro Panel

Micro Panel	VDC	Ic	Ip
ACJ-055-09	20 - 55	3	9
ACJ-055-18	20 - 55	6	18
ACJ-090-03	20 - 90	1	3
ACJ-090-09	20 - 90	3	9
ACJ-090-12	20 - 90	6	12



Accelnet Module

Module	VDC	Ic	Ip
ACM-055-18	20 - 55	6	18
ACM-090-09	20 - 90	3	9
ACM-180-09	20 - 180	3	9
ACM-180-18	20 - 180	6	18
ACM-180-20	20 - 180	10	20



Accelnet Micro Module

Mic. Mod.	VDC	Ic	Ip
ACK-055-06	20 - 55	3	6
ACK-090-04	20 - 90	2	4

Control Modes

CANopen: PVT, Profile position/velocity/torque, Homing
Indexer, Position, Velocity, Torque

Command Interface

CANopen
Ascii and discrete I/O
Stepper commands
 $\pm 10V$ & PWM velocity and torque command
Master encoder (electronic gearing)

Communications

CAN, RS232

Feedback

Digital quad A/B encoder, Digital Halls
Secondary encoder / emulated encoder out (Panel versions)
Analog sin/cos encoder (Panel versions)

I/O - Digital

8-12 inputs, 2-3 outputs

Dimensions

Panel: 168 x 176 x 31 mm (6.6 x 3.9 x 1.2 in)
Micro Panel: 97 x 64 x 33 mm (3.8 x 2.5 x 1.3 in)
Module: 102 x 69 x 25 mm (4.0 x 2.7 x 1.0 in)
Micro Module: 64 x 41 x 16 mm (2.5 x 1.6 x 0.6 in)

Stepnet

Digital CANopen Amplifier for Stepper Motors



Stepnet Panel

Panel	VDC	Ic	Ip
STP-075-07	20 - 75	5	7



Stepnet Module

Module	VDC	Ic	Ip
STM-075-07	20 - 55	5	7



Stepnet Micro Module

Mic. Mod.	VDC	Ic	Ip
STL-055-04	20 - 55	3	4.5
STL-075-03	20 - 75	2	3

Control Modes

CANopen: PVT, Profile position/velocity/torque, Homing
Indexer, Position, Velocity

Command Interface

CANopen
Ascii and discrete I/O
Stepper commands
PWM velocity and torque command
Master encoder (electronic gearing)

Communications

CAN
RS232

Feedback

Digital quad A/B encoder

I/O - Digital

12 inputs, 4 outputs

Dimensions

Panel: 138 x 78 x 39 mm (5.4 x 3.1 x 1.5 in)
Module: 102 x 69 x 25 mm (4.0 x 2.7 x 1.0 in)
Micro Module: 64 x 41 x 16 mm (2.5 x 1.6 x 0.6 in)

Accelus

Digital Amplifier for Brushless/Brush Motors



Accelus Panel

Panel	VDC	Ic	Ip
ASP-055-18	20 - 55	6	18
ASP-090-09	20 - 90	3	9
ASP-090-18	20 - 90	6	18
ASP-090-36	20 - 90	12	36
ASP-180-09	20 - 180	3	9
ASP-180-18	20 - 180	6	18



Accelus Card

Card	VDC	Ic	Ip
ASC-055-18	20 - 55	6	18
ASC-090-09	20 - 90	3	9

Control Modes

Position, Velocity, Torque

Command Interface

Stepper commands

±10V velocity and torque command

PWM velocity and torque command

Master encoder (electronic gearing)

Communications

RS232

Feedback

Digital quad A/B encoder

Digital Halls

I/O - Digital

6 inputs, 2 outputs

Dimensions

Panel: 168 x 99 x 31 mm (6.6 x 3.9 x 1.2 in)

Card: 153 x 89 x 31 mm (6.0 x 3.5 x 1.2 in)

Junus

Digital Amplifier for Brush Motors



Panel	VDC	Ic	Ip
JSP-090-10	20 - 90	5	10
JSP-090-20	20 - 90	10	20
JSP-180-10	20 - 180	5	10
JSP-180-20	20 - 180	10	20

Control Modes

Velocity, Torque

Command Interface

±10V velocity and torque command

PWM velocity and torque command

Communications

RS232

Feedback

Back-Emf (velocity mode)

I/O - Digital

5 inputs, 1 output

Dimensions

130 x 82 x 31 mm (5.1 x 3.2 x 1.2 in)

Analog Servo Amplifiers

Copley offers a complete range of analog amplifiers for brushless, brush and voice coil motors. 7 Series sinusoidal amplifiers accept externally commutated UV current commands. 5 Series trapezoidal amplifiers commute from Halls. 4 Series brush/voice coil amplifiers accept tachometer feedback for velocity mode operation. See www.copleycontrols.com for a full range of accessories.



7 Series
Sinusoidal torque amplifiers
for brushless motors



5 Series
Trapezoidal torque/velocity amplifiers
for brushless motors



4 Series
Torque/velocity amplifiers
for brush motors

	7 SERIES		5 SERIES		4 SERIES	
	7xx5AC	7225x	5xx4AC	503	4xx	4xx2
Motor	Brushless	Brushless	Brushless	Brushless	Brush	Brush
Commutation	Sinusoidal	Sinusoidal	Trapezoidal	Trapezoidal	NA	NA
Input Power	100 - 240 VAC	24 - 180 VDC	100 - 240 VAC	18 - 55 VDC	24 - 180 VDC	24 - 125 VDC
Continuous Current	10 A	10 - 15 A	10 - 15 A	5 A	10 - 15 A	6 - 10 A
Torque Mode	Yes	Yes	Yes	Yes	Yes	Yes
Velocity Mode	No	No	Yes	No	Yes	No
±10V	No	No	Yes	Yes	Yes	Yes
UV	Yes	Yes	No	No	No	No
Feedback	None	None	Encoder Digital Halls Back-Emf	Digital Halls	Tach. Back-Emf	None

7x25AC

100-240 VAC UV Torque Amplifier for Brushless Motors



Model	VAC	Ic	Ip
7225AC	100 - 120	10	20
7425AC	100 - 240	10	20

Internal edge filter option: append F

Control Modes

Torque

Command Interface

UV externally commutated torque commands

Current limit

Feedback

None

Configuration

Potentiometers

DIP switch

Solderless component header (preconfigured option)

I/O

Digital inputs: reset, enable, motor overtemperature

Digital outputs: amp OK, normal, current limited

Analog monitor: actual current (U and V)

Dimensions

191 x 176 x 69 mm (7.5 x 6.9 x 2.7 in)

7225x

Low Drift 1-2 Axis UV Torque Amplifier for Brushless Motors



1 Axis	VDC	Ic	Ip
7225X1	24 - 180	10	25
7225X1-50	24 - 180	15	50

2 Axis	VDC	Ic	Ip
7225X2	24 - 180	10	25

Control Modes

Torque

Command Interface

UV externally commutated torque commands

Feedback

None

Configuration

Potentiometers

Solderless component header (preconfigured option)

I/O

Digital inputs: reset, enable, motor overtemperature

Digital outputs: amp OK, normal, current limited

Analog monitor: actual current (U and V)

Dimensions

X1: 186 x 112 x 39 mm (7.3 x 4.4 x 1.5 in)

X2: 249 x 125 x 46 mm (9.8 x 4.9 x 1.8 in)

5xx4AC

100-240 VAC Torque/Velocity Amplifier for Brushless Motors



Model	VAC	Ic	Ip
5224AC*	100 - 120	10	20
5234AC	100 - 120	15	30
5424AC*	100 - 240	10	20
5434AC	100 - 240	15	30

*Internal edge filter option: append F

Control Modes

Velocity, Torque

Command Interface

±10V velocity and torque command

Feedback

Digital quad A/B encoder

Digital Halls

Back-Emf

Configuration

Potentiometers

DIP switch

Solderless component header (preconfigured option)

I/O

Digital inputs: mode select, reset, enable, limits

Digital outputs: amp OK, normal

Analog monitor: actual current, commanded current, velocity

Dimensions

191 x 176 x 69 mm (7.5 x 6.9 x 2.7 in)

503

Torque Amplifier for Brushless Motors



Model	VDC	Ic	Ip
503	18 - 55	5	10

Control Modes

Torque

Command Interface

±10V torque command

Feedback

Digital Halls

Configuration

Solderless component header (preconfigured option)

I/O

Digital inputs: reset, enable, enable polarity, limits

Digital output: amp OK

Analog monitor: actual current

Dimensions

120 x 84 x 33 mm (4.7 x 3.3 x 1.3 in)

4xx

Torque/Velocity Amplifier for Brush Motors



Model	VDC	Ic	Ip
412CE	24 - 90	10	20
413CE	24 - 90	15	30
421CE	24 - 180	5	10
422CE	24 - 180	10	20

Control Modes	Velocity, Torque
Command Interface	±10V velocity and torque command
Feedback	Brush-tachometer Back-Emf
Configuration	Potentiometers DIP switch Solderless component header (preconfigured option)
I/O	Digital inputs: reset, enable, limits Digital outputs: fault
Dimensions	Analog monitor: actual current, commanded current, load voltage 130 x 84 x 36 mm (5.1 x 3.3 x 1.4 in)

4xx2

Torque Amplifier for Brush Motors and Voice Coils



Model	VDC	Ic	Ip
4122Z	24 - 90	10	20
4212Z	24 - 125	6	12

Control Modes	Torque
Command Interface	±10V torque command
Feedback	None
Configuration	Potentiometers Solderless component header (preconfigured option)
I/O	Digital inputs: reset, enable, limits Digital outputs: fault
Dimensions	Analog monitor: actual current, commanded current 110 x 77 x 26 mm (4.3 x 3.0 x 1.0 in)

Custom OEM Solutions

Copley provides competitive advantage to the OEM by tailoring designs to precisely fit the application. Our experienced engineering and applications team can work with you to define the right solution. Customization can be as simple as specialized I/O functions or as complex as a complete, cost-optimized multi-axis system.

Enhanced Firmware
Advanced filters and servo/stepper algorithms

Optimized Packaging
Special connectors and optimized form factor

Multi-Axis Solutions
Rack based systems and 2-3 axis packages

Performance Edge
Low noise and temperature compensation for precision applications

OEM Solution

Custom Java Beans
Java functions for powerful control programs



3 Axis Torque Amplifier

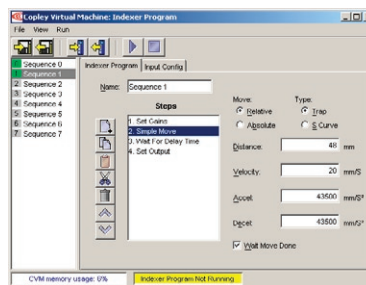

Custom Indexer Function



Eurocard with Edge Filter

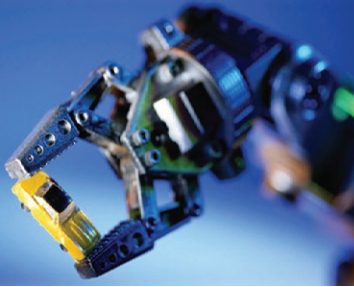

Motor Technology

Industrial ServoTube achieves 12 micron repeatability from a built-in sensor. A linear encoder is not required. Actuators incorporate long-life dry bearings and accept standard mounting accessories. **Precision ThrustTube** motors are available as components or modules with built-in linear encoders and precision bearings.

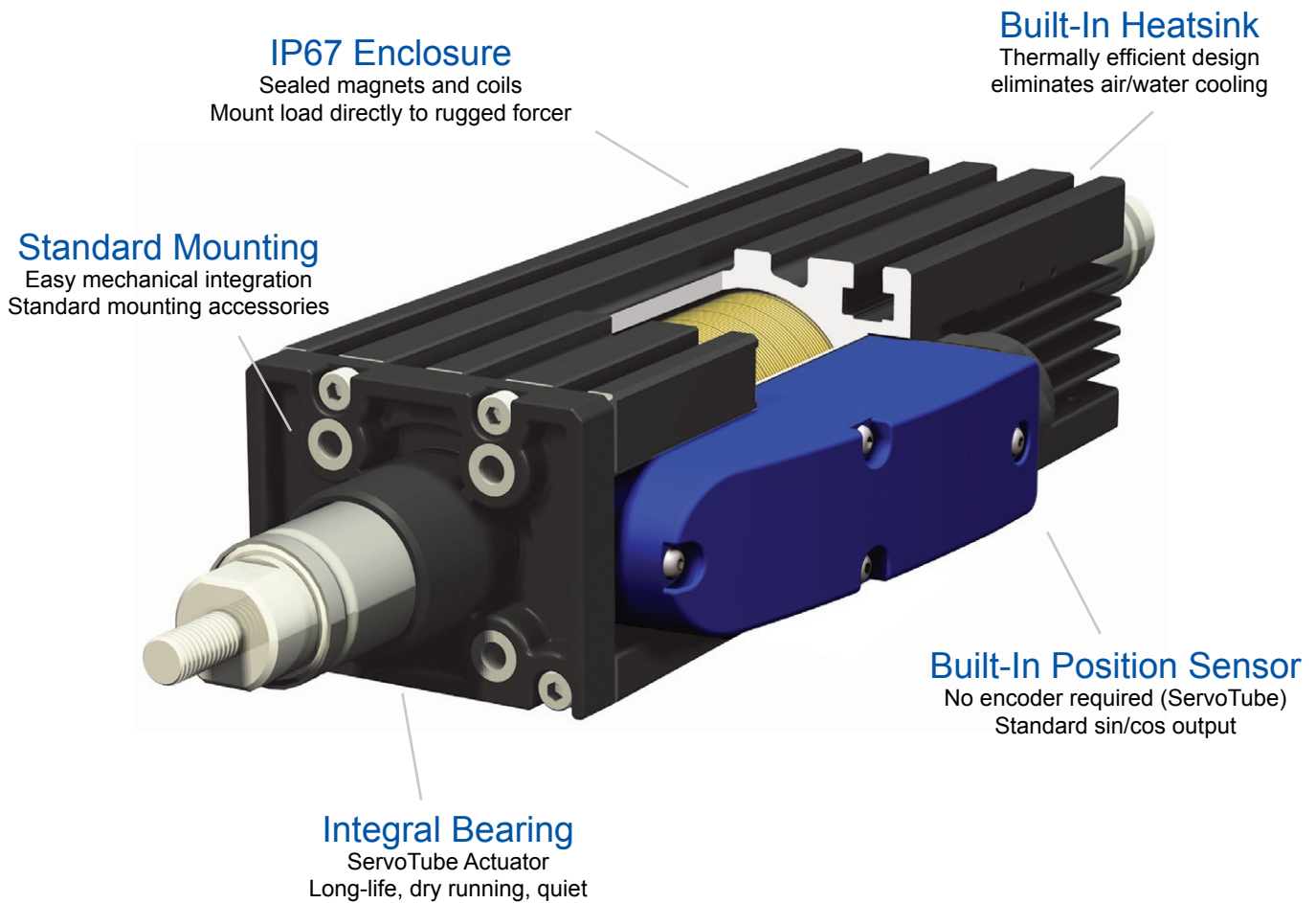

The Tubular Motor

The symmetrical design of the tubular motor is magnetically efficient and unaffected by misalignment. A large air gap simplifies installation.

The tubular motor has superior thermal efficiency, radiating heat uniformly. High duty cycles are possible without forced-air or water cooling.

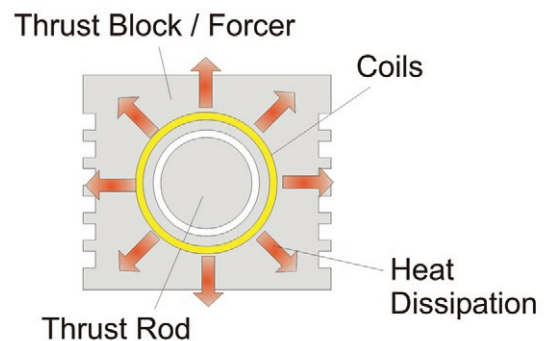

ServoTube Actuator & Components

ServoTube delivers the speed and ruggedness of pneumatics, the controllability of a ballscrew and the high reliability of a linear motor. The patented magnetic design delivers up to 12 micron repeatability and 250 micron accuracy from a non-contact, integral sensor. ServoTube is available as an actuator (moving rod) with integral bearings and as OEM components (moving block). An optional holding brake and high rigidity version are available for the actuator. System integration is simple with a matched Xenus servo-amplifier and industry standard mounting accessories.

ServoTube

Motor Components

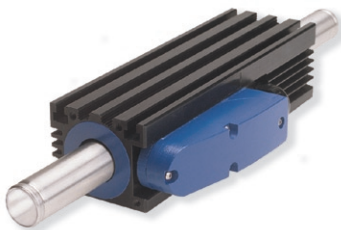

		2504	2506	2508	2510
Peak Force	N / lb	312 / 70	468 / 105	624 / 140	780 / 175
Continuous Force	N / lb	51 / 12	70 / 16	87 / 19	102 / 23
Force Constant	N/Arms	22.1	33.1	44.1	55.2
Back-emf Constant	Vpk/m/s	18	27	36	45
Maximum Velocity	m/s	8.7	6.5	5.4	4.6
Maximum Acceleration	m/s/s	223	223	235	256
Maximum Travel	mm	1186	1135	1084	1033
Forcer Width x Height	mm			95 x 54	
Rod Diameter	mm			25	

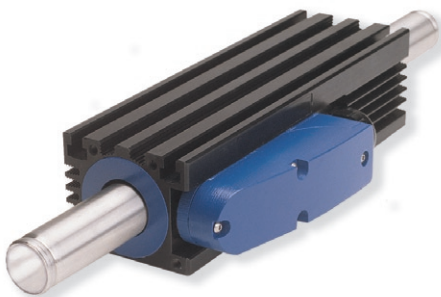

		3804	3806	3808	3810
Peak Force	N / lb	744 / 167	1116 / 251	1488 / 334	1860 / 418
Continuous Force	N / lb	156 / 35	206 / 46	247 / 56	293 / 66
Force Constant	N/Arms	52.6	78.9	105.2	131.5
Back-emf Constant	Vpk/m/s	43.0	64.4	85.9	107.4
Maximum Velocity	m/s	6.0	4.4	3.4	2.8
Maximum Acceleration	m/s/s	292	314	331	335
Maximum Travel	mm	1362	1291	1220	1149
Forcer Width x Height	mm			122 x 70	
Rod Diameter	mm			38	

ServoTube Actuator

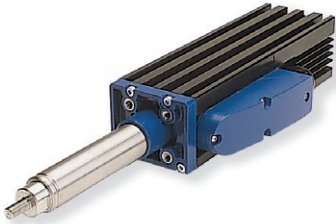

		2504	2506	2508	2510
Peak Force	N / lb	312 / 70	468 / 105	624 / 140	780 / 175
Continuous Force	N / lb	51 / 11	70 / 16	87 / 20	104 / 23
Force Constant	N/Arms	22	33	44	55
Back-emf Constant	Vpk/m/s	18	27	36	45
Maximum Velocity	m/s	5.9	5.3	4.7	4.2
Maximum Acceleration	m/s/s	394	483	542	586
Stroke	mm		26 - 309		
Forcer Width x Height	mm		95 x 54		
Rod Diameter	mm		25		

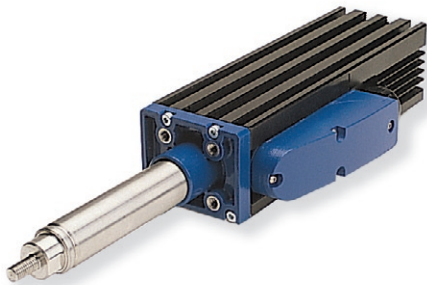

		3804	3806	3808	3810
Peak Force	N / lb	744 / 167	1116 / 251	1488 / 334	1860 / 418
Continuous Force	N / lb	156 / 35	206 / 46	247 / 56	293 / 66
Force Constant	N/Arms	52.6	78.9	105.2	131.5
Back-emf Constant	Vpk/m/s	43.0	64.4	85.9	107.4
Maximum Velocity	m/s	4.6	3.7	3.1	2.6
Maximum Acceleration	m/s/s	298	361	404	435
Stroke	mm		33 - 318		
Forcer Width x Height	mm		122 x 70		
Rod Diameter	mm		38		

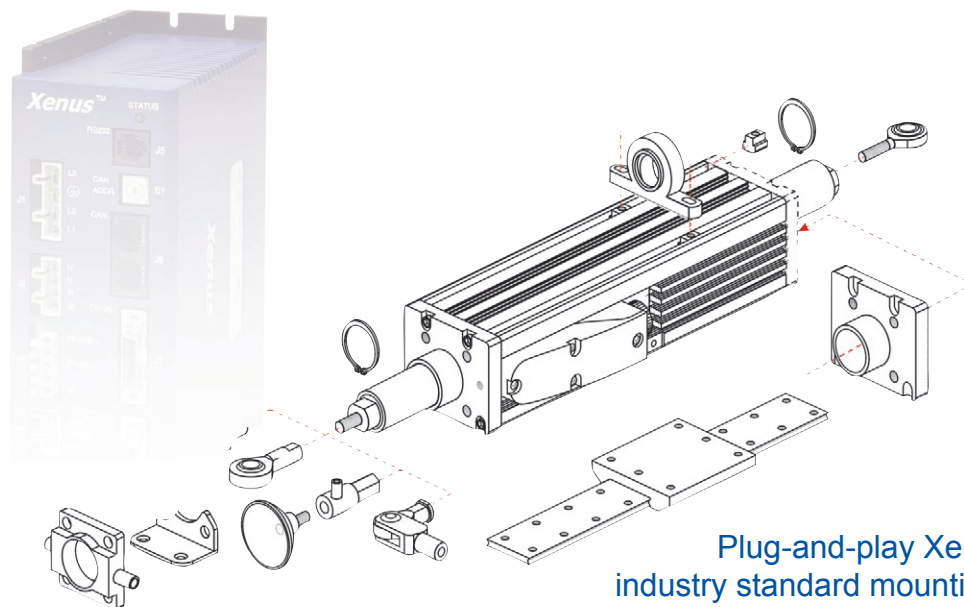

Plug-and-play Xenus and industry standard mounting accessories

Precision Modules & Components

Zero-cogging, ironless design provides 4-250 N (1-56 lb) continuous force at speeds up to 14 m/sec. Higher force iron core is optional. Load can be mounted directly to forcer for easy mechanical integration. Available as motor components or ready-to-use modules with integrated bearings and encoder. Bellows and nickel plating (washdown) are optional.

ThrustTube

Motor Components

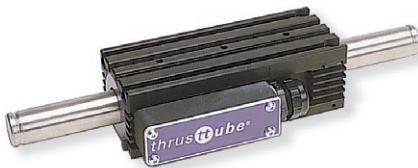

		2504	2506	2508	2510
Peak Force	N / lb	312 / 70	468 / 105	624 / 140	780 / 175
Continuous Force	N / lb	51 / 12	70 / 16	87 / 19	102 / 23
Force Constant	N/Arms	22.1	33.1	44.1	55.2
Back-emf Constant	Vpk/m/s	18	27	36	45
Maximum Velocity	m/s	9.3	6.9	5.7	4.8
Maximum Acceleration	m/s/s	215	208	227	240
Maximum Travel	mm	1214	1161	1150	1059
Forcer Width x Height	mm		98 x 54		
Rod Diameter	mm		25		

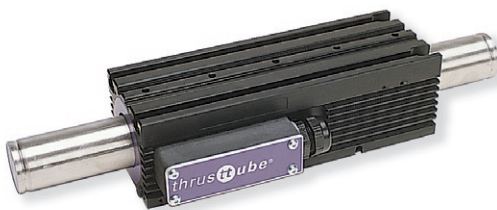

		3804	3806	3808	3810
Peak Force	N / lb	704 / 158	1056 / 237	1408 / 316	1522 / 342
Continuous Force	N / lb	122 / 27	167 / 38	210 / 47	249 / 56
Force Constant	N/Arms	49.8	74.7	99.6	124.4
Back-emf Constant	Vpk/m/s	40.0	61.0	81.3	101.6
Maximum Velocity	m/s	5.3	3.8	3.0	2.4
Maximum Acceleration	m/s/s	243	271	287	258
Maximum Travel	mm	1368	1297	1226	1155
Forcer Width x Height	mm		115 x 70		
Rod Diameter	mm		38		

TT Micro

Motor Components



		1102	1104	1106	1108
Peak Force	N / lb	19 / 4	38 / 9	57 / 13	68 / 15
Continuous Force	N / lb	4 / 1	7 / 2	11 / 2.5	14 / 3
Force Constant	N/Arms	2.7	5.4	8.1	10.8
Back-emf Constant	Vpk/m/s	2.2	4.4	6.6	8.8
Maximum Velocity	m/s	10.6	8.6	6.5	5.2
Maximum Acceleration	m/s/s	251	290	309	275
Maximum Travel	mm	454	428	403	377
Forcer Width x Height	mm	41 x 25			
Rod Diameter	mm	11			

TT Micro and ThrustTube

Modules

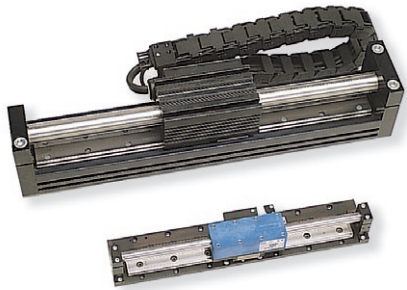

		TB11	TB25	TB38
Max. Travel	mm	510	1212	1368
Width x Height	mm	65 x 49	151 x 94	154 x 110
Digital Encoder	um	0.1 - 5	0.1 - 5	0.1 - 5
Sin/Cos Encoder Pitch	um	20	20-1000	20-1000

Modules combine easily into
multi-axis gantries

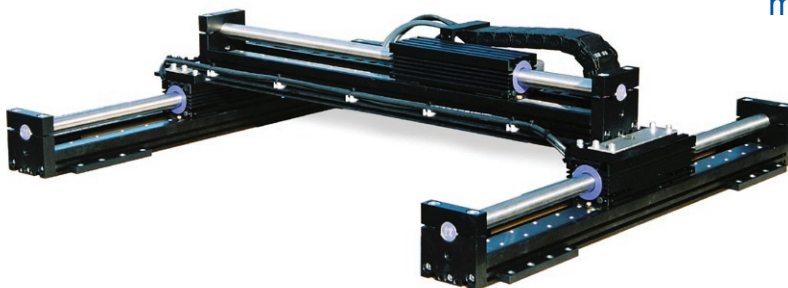



Copley Motion Systems LLC

World Headquarters

20 Dan Road
Canton, MA 02021, USA
Tel: 781-828-8090
www.copleycontrols.com

European Headquarters

Luckyn Lane
Basildon, SS14 3BW, UK
Tel: (44) (0)1268 287070
www.copleycontrols.com