

# Triplexsense

TR-3



NEW

## We create a brand new kind of skin counseling.

Each client has her own character and age.  
The beauty of our skin has different qualities as we age.  
Our skin has its own beauty in every age.  
The Triplexsense is a new item for enhancing the beauty of skin at all ages.  
When you enter your age into the Triplexsense you receive an assessment of your skin condition comparing it to data on average skin conditions for your age group.  
Through its combining measurements for skin oil content, moisture and elasticity, a perfect device is born.



Skin oil content counter

Skin moisture counter

Skin elastic counter

### Skin oil content, moisture and elasticity. We take a sensor scan of three categories

Counseling, based on the data received in the scan of oil content, moisture and elasticity can be offered much more accurately and smoothly than was before possible.

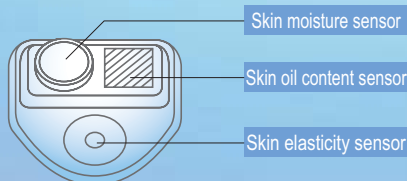

Skin moisture sensor

Skin oil content sensor

Skin elasticity sensor

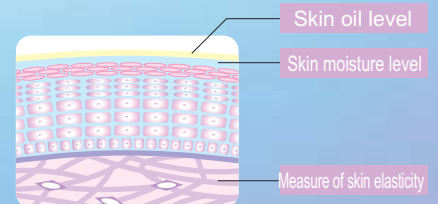

Skin oil level

Skin moisture level

Measure of skin elasticity

The way to skin counseling

# A perfect device to assist in caring for our aging skin

- H** Good
- M** Normal
- L** Problem skin
- M** Skin moisture content
- O** Skin oil content
- E** Skin elasticity

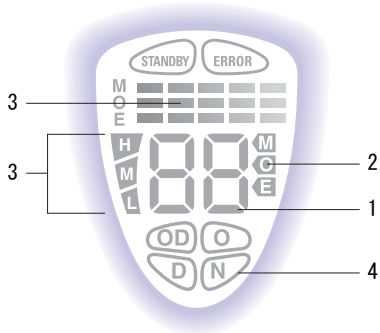

## Triplesense

TR-3

### 1. The results of the assessment are compared with data collected for each age.

Upon entering your age the "Triplesense" assesses your current skin condition comparing it with the average data of others in your age range.

### 2. This one device has three functions.

The content of oil (O) and moisture (M) and the elasticity (E) of your skin can be measured with this one device. This excellent product shows the balance of oil and moisture in your skin and measures its elasticity, too.

### 4. Easy to identify skin type

You can easily identify your skin type, normal (N), oily (O), dry (D) and oily-dry (OD).

### 3. Easy to read measurement display

It's easily identifiable indicator display shows at a glance the balance of the three categories based on those measurements and it indicates the result from 0-99 in three levels, H (high), M (medium) and L (low).

### 5. Portable, you can use it anywhere.

It is very convenient to carry it; it's cordless so you can use it anywhere.

## Specifications / features

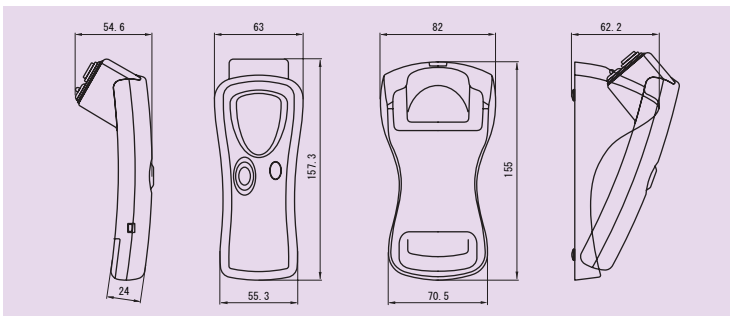

Method used in measurement:	Oil content > Optical system Moisture content > Electrical capacitance system Elasticity > Supersonic vibration system
Labeling method	Oil content, moisture content, elasticity Double-digit 0-99 level
Power source	2 AAA batteries (alkali cell recommended)
Power consumption	25mA
Weight	Approximately 115g (without batteries)

**MORITEX CORPORATION**  
Cosmetic-Art Business-Division

6862 Santa Teresa Blvd. San Jose, CA 95119  
Phone: (877) 261-2100 Fax: (408) 363-9980

email: [esthetics@moritexusa.com](mailto:esthetics@moritexusa.com)  
[www.moritexusa.com](http://www.moritexusa.com)