

OA 機器用

24W



DC MOTOR

TS3063

() inch

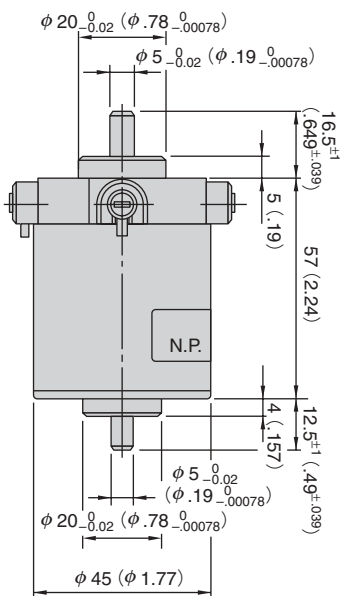
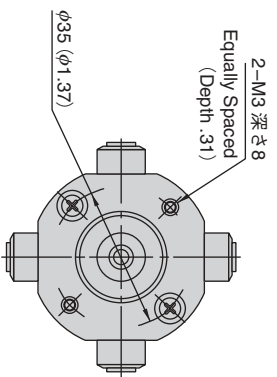

仕様

SPECIFICATIONS

形式 TS3063 (モータのみ)

モ ー タ MOTOR	(定格点) 出力	Rated Output (P _R)	24W
	(定格点) トルク	Rated Torque (T _R)	9.8×10 ⁻² N·m(1.0kgf·cm)
	(定格点) 回転数	Rated Speed (N _R)	2,300min ⁻¹
	最大回転数	Max. Speed (N _{max.})	3,800min ⁻¹
	定格点電圧	Rated Voltage (E _R)	26V
	定格点電流	Rated Current (I _R)	1.5A
	無負荷電流	No Load Current (I ₀)	0.25A Max.
	電機子イナーシャ	Armature Moment of Inertia (I _R)	0.10×10 ⁻⁴ kg·m ² (0.10gf·cm·sec ²)
	トルク定数	Torque Constant (K _T)	7.8×10 ⁻² N·m(0.8kgf·cm) /A
	誘起電圧定数	Voltage Constant (K _E)	8.2×10 ⁻³ V/(min ⁻¹)±10%
	電機子抵抗(端子間)	Armature Resistance (R _a)	5.3Ω±15%
	電機子インダクタンス	Armature Inductance (L _a)	3.0mH±15%
	機械的時定数	Mechanical Time Constant (τ _m)	8.5m sec
	電氣的時定数	Electrical Time Constant (τ _e)	0.57m sec
	熱抵抗	Thermal Resistance (R _{th})	5.0°C/W
	最大電機子温度	Allowable Max. Armature Temp.	130°C
	軸摩擦トルク	Friction Torque (F _r)	1.47×10 ⁻² N·m(0.15kgf·cm) Max.
	瞬時最大電流	Instantaneous Peak Current (I _p)	3.6A
	瞬間最大トルク	Instantaneous Peak Torque (T _p)	0.23N·m(2.3kgf·cm)
	定格パワーレート	Rated Power Rate	0.98kW/sec
絶縁抵抗	Insulation Resistance	10MΩ Min. at 500V DC Megger	
絶縁耐力	Dielectric Strength	60sec at 50/60Hz 500V	
軸方向遊び	Shaft End play	0.03mm Max. (1kgf Load)	
質量	Mass (W _M)	200g Max.	

連続定格領域 CONTINUOUS RATING AREA

