

EC 45 Ø45 mm, brushless, 150 Watt, CE approved

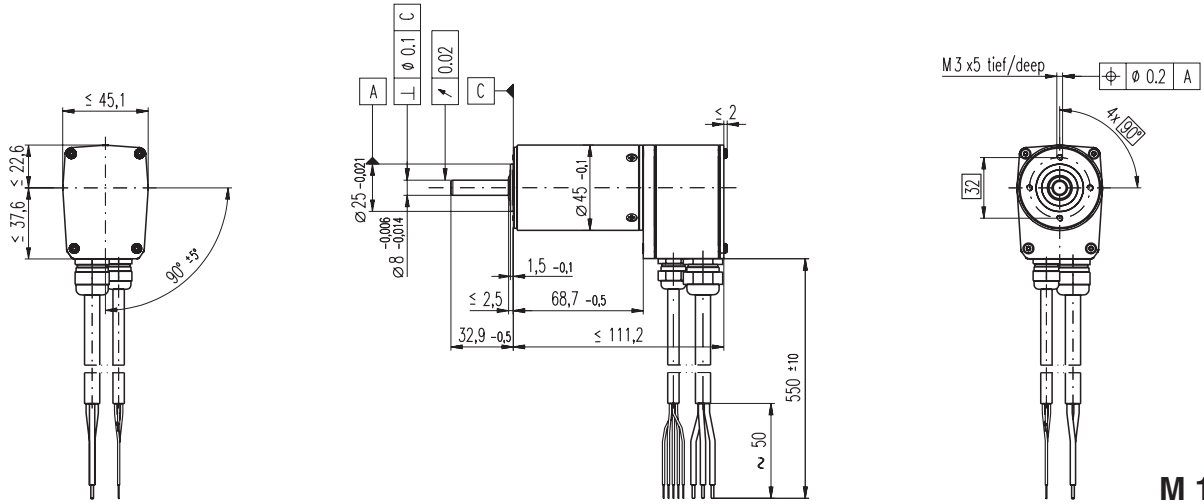

- Stock program
- Standard program
- Special program (on request)

Order Number

136202	136196	136203	136197	136204	136198	136205	136200	136206	136201
--------	--------	--------	--------	--------	--------	--------	--------	--------	--------

Motor Data

Values at nominal voltage												
1	Nominal voltage	V	12.0	12.0	18.0	18.0	24.0	24.0	36.0	36.0	48.0	48.0
2	No load speed	rpm	9770	5630	10300	5920	10500	6070	9340	5380	10100	5850
3	No load current	mA	1860	722	1350	522	1060	409	572	223	496	192
4	Nominal speed	rpm	8610	4430	9100	4710	9360	4860	8180	4200	8980	4650
5	Nominal torque (max. continuous torque)	mNm	168	182	165	181	163	179	174	188	168	183
6	Nominal current (max. continuous current)	A	16.0	9.61	11.1	6.69	8.45	5.10	5.24	3.13	4.16	2.51
7	Stall torque	mNm	1590	916	1650	955	1670	965	1590	916	1670	965
8	Starting current	A	138	45.8	100	33.4	78.0	26.0	43.8	14.6	37.6	12.5
9	Max. efficiency	%	79	77	79	77	79	77	79	77	79	77
Characteristics												
10	Terminal resistance phase to phase	Ω	0.0873	0.262	0.180	0.539	0.308	0.923	0.823	2.47	1.28	3.83
11	Terminal inductance phase to phase	mH	0.0266	0.0797	0.0542	0.163	0.0917	0.275	0.263	0.788	0.395	1.19
12	Torque constant	mNm / A	11.5	20.0	16.5	28.6	21.4	37.1	36.3	62.8	44.5	77.1
13	Speed constant	rpm / V	827	478	579	334	445	257	263	152	214	124
14	Speed / torque gradient	rpm / mNm	6.25	6.25	6.30	6.30	6.39	6.39	5.97	5.97	6.16	6.16
15	Mechanical time constant	ms	7.79	7.79	7.86	7.86	7.97	7.97	7.44	7.44	7.67	7.67
16	Rotor inertia	gcm ²	119	119	119	119	119	119	119	119	119	119

Specifications

- Thermal data**
- 17 Thermal resistance housing-ambient 1.9 K / W
 - 18 Thermal resistance winding-housing 0.9 K / W
 - 19 Thermal time constant winding 15 s
 - 20 Thermal time constant motor 1600 s
 - 21 Ambient temperature -20 ... +100°C
 - 22 Max. permissible winding temperature +125°C
- Mechanical data (preloaded ball bearings)**
- 23 Max. permissible speed 15000 rpm
 - 24 Axial play at axial load < 20 N 0 mm
 - > 20 N max. 0.14 mm
 - 25 Radial play preloaded
 - 26 Max. axial load (dynamic) 20 N
 - 27 Max. force for press fits (static) 170 N
 - (static, shaft supported) 5000 N
 - 28 Max. radial loading, 5 mm from flange 140 N

Operating Range

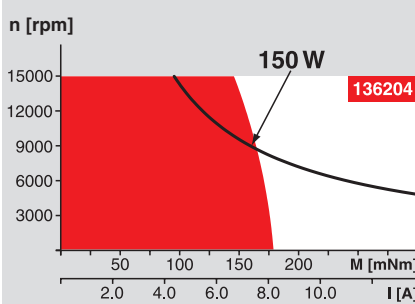

Comments

- Continuous operation**
In observation of above listed thermal resistance (lines 17 and 18) the maximum permissible winding temperature will be reached during continuous operation at 25°C ambient.
= Thermal limit.
- Short term operation**
The motor may be briefly overloaded (recurring).
- **Assigned power rating**

Other specifications

- 29 Number of pole pairs 1
- 30 Number of phases 3
- 31 Weight of motor 850 g
- Protection to IP54

Values listed in the table are nominal.

Connection Motor (Cable AWG 16)

- Cable 1 Motor winding 1
- Cable 2 Motor winding 2
- Cable 3 Motor winding 3

Connection Sensors (Cable AWG 24)

- white Hall sensor 3
- brown Hall sensor 2
- green Hall sensor 1
- yellow GND
- grey V_{Hall} 4.5 ... 24 VDC

Wiring diagram for Hall sensors see page 26

Option

- Temperature monitoring, PTC resistance Micropille
- 110°C, R 25°C < 0.5 kΩ, R 105°C = 1.2 ... 1.5 kΩ,
- R 115°C = 7 ... 13 kΩ, R 120°C = 18 ... 35 kΩ,
- Motor connection with plug

maxon Modular System

Overview on page 16 - 21

Planetary Gearhead

- Ø42 mm
- 3 - 15 Nm
- Page 235

Planetary Gearhead

- Ø52 mm
- 4 - 30 Nm
- Page 238

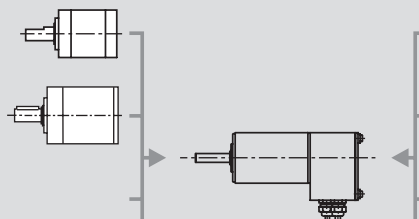

Recommended Electronics:

- DEC 50/5 Page 277
- DECV 50/5 278
- DEC 70/10 278
- DES 50/5 279
- DES 70/10 279
- EPOS 70/10 287
- MIP 50 289
- MIP 100 289
- Notes 20

Encoder HEDL 9140

- 500 CPT,
- 3 channels
- Page 259

Resolver Res 26

- Ø26 mm
- 10 V
- Page 264

Brake AB 28

- Ø28 mm, 24 VDC
- 0.4 Nm
- Page 301