



Standard version. Anthropomorphic robot with six axes, suitable for painting in line, where exist air or floor conveyor systems. Thanks to its structure it is possible to work pieces of great dimensions; if necessary it is synchronized to the conveyor for running after the pieces. When the pieces have considerable dimensions, the robots are set up on translation carts, which can have different measures.

GR-630 ST



TECHNICAL FEATURES	
PHISICAL	
Number of robot axes	6
Number of external axes	6
Working area	2.100
Wrist capacity	3 kg
Installation	Floor/Ceiling/Wall/Cart
Programmation	Self teaching – PTP – Off Line
Robot weight	490 kg
ENVIRONMENT	
Robot protection degree	IP 65
Robot Explosion protection (Atex)	Category: II 2 G EEx p II T4
OPTION	
Sincronizzazione al trasportatore	
Line Tracking	
Automatic control of the spray parameters	
Tele service	
Off-Line	
ATEX	



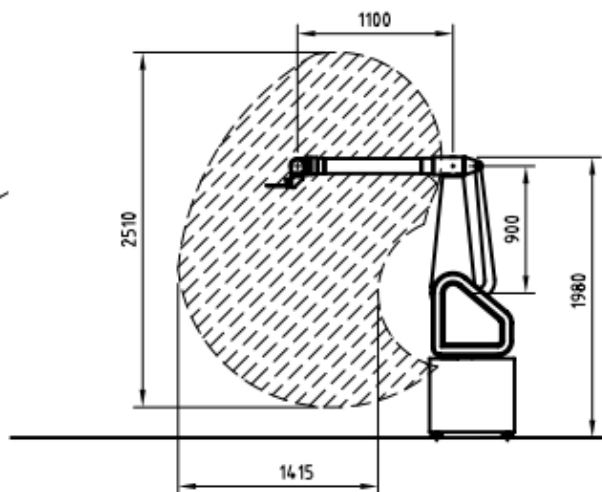
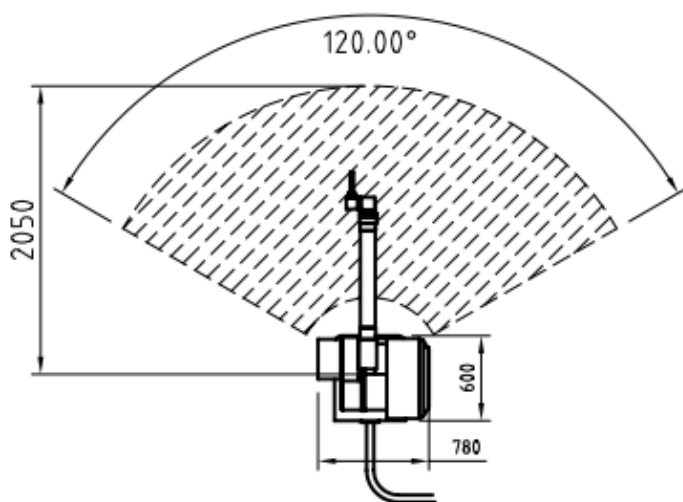

GR-630 G

Version with carousel, robot complete with two, three or four arms. The arms are provided with rotation group synchronized with the robot, can be prepared with various pieces supports as needed. The pieces are loaded manually or automatically in a safe zone, the carousel turn in to the front position for painting , and brings them back into the discharge zone. Thanks to the configuration of the arms allows to perform the programming in a very smooth. The rotation of the carousel takes place by means of controlled axis with programmable speed adjustment.

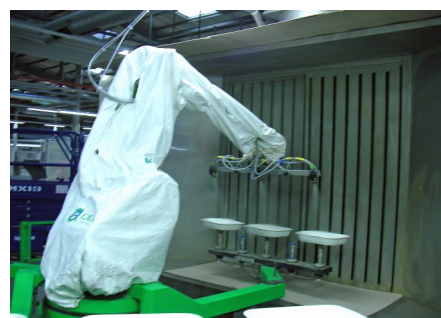

TECHNICAL FEATURES	
CARROUSEL	
Movement	Servo controlled
Arms number	2-3-4
Arm weight capacity	50 kg
Robot weight	840 Kg
RUOTA PEZZO	
Movement	Servo controlled and synchronized
OPTIONS	
Adjustable piece supports	

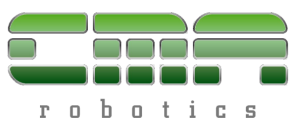

CMA Robotics Spa
Via P.P. Pasolini 35/15
33040 Pradamano (UD) Italy
www.cmarobot.it - info@cmarobot.it