

# MOUNTING COMPONENTS

## Adjustable Joint and Steel Corner Braces — Standard & [Miniature]

### Adjustable Joint Connector

Suggested hardware SCH8-06 screw with T-Nuts (2).

**Material:** Aluminum

**Finish:** Clear Anodize

**SCB2**

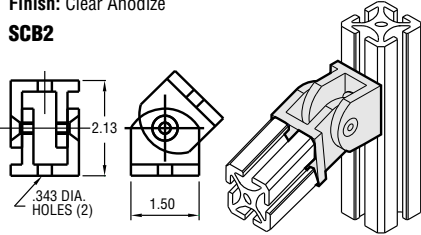

### Reinforced Corner Brace

Suggested hardware SCH9-06 screw and SCH1 nut (4).  
[SCH9M-04 screw and SCH1M nut (4)]

**Material:** Alloy Steel

**Finish:** Black Powder Coat

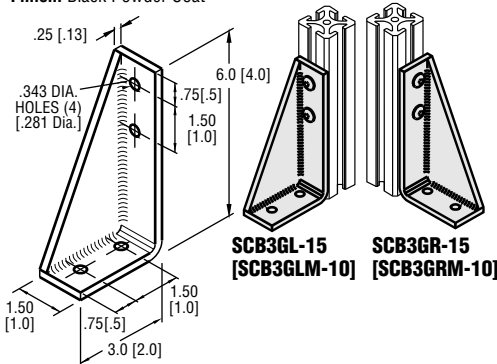

### Corner Brace

Suggested hardware SCH9-06 screw and SCH1 nut (4).  
[SCH9M-04 screw and SCH1M nut (4)]

**Material:** Alloy Steel

**Finish:** Black Powder Coat

**SCB3-15**  
**[SCB3M-10]**

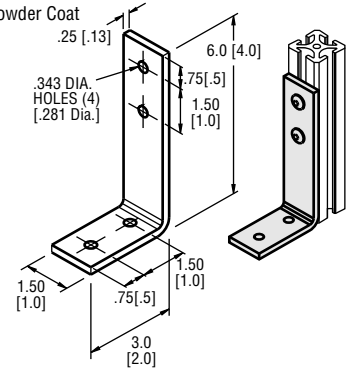

### Corner Brace Reinforced

Suggested hardware SCH9-06 screw and SCH1 nut (8).  
[SCH9M-04 screw and SCH1M nut (8)]

**Material:** Alloy Steel

**Finish:** Black Powder Coat

**SCB4G-30**  
**[SCB4GM-20]**

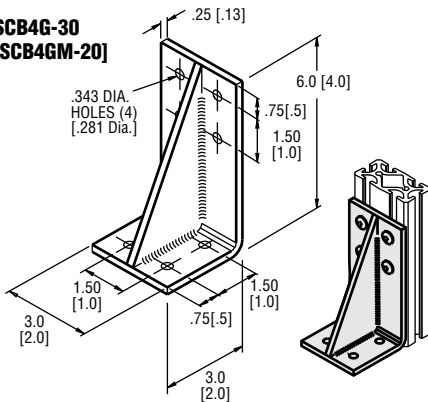

### Corner Brace

Suggested hardware SCH9-06 and SCH1 nut (8).  
[SCH9M-06 screw and SCH1M nut (8)]

**Material:** Alloy Steel

**Finish:** Black Powder Coat

**SCB5-30**  
**[SCB5M-20]**

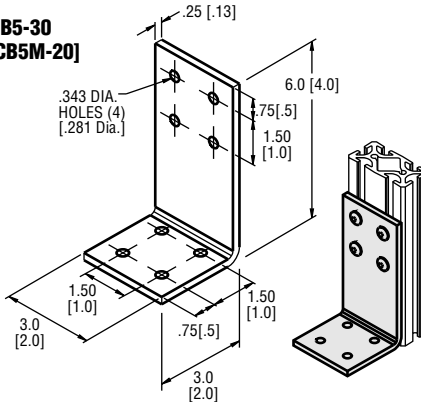

### Corner Block

**Material:** Aluminum

**Finish:** Clear Anodize

**SCB6**  
**[SCB6M]**

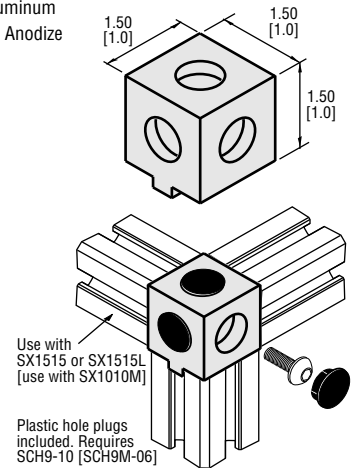

# FASTENING HARDWARE — STANDARD & [MINIATURE]

### Pivot T-Nuts

Loads into extrusion from the side.  
Not to be used on SX1010L and SX1015L.

**SCH1-P**  
**[SCH1M-P]**

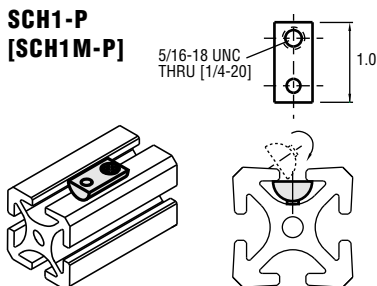

**Material:** Alloy Steel  
**Finish:** Zinc Plate

### Connector T-Nuts

Loads into extrusion from end only.

**SCH1**

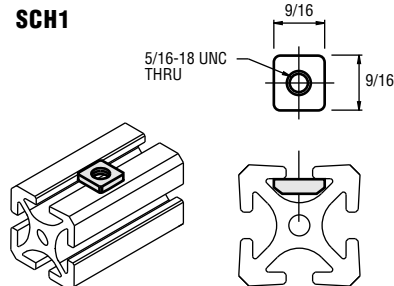

### Economy T-Nuts

**SCH2-15** Long T-Nut  
**[SCH2M-15]**

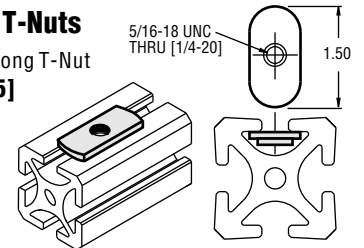

**SCH2-10** T-Nut  
**[SCH2M-10]**

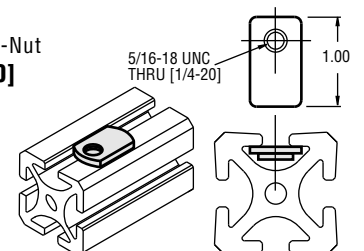

# FASTENING HARDWARE

## Standard Connectors

### Single Cross Connector

Hardware Included.

**SCH3**

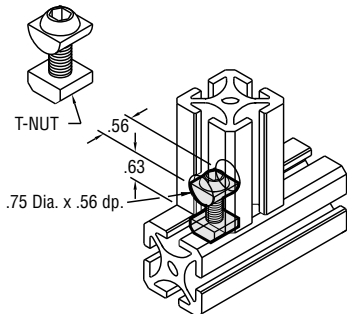

### Double Cross Connector

Hardware Included.

**SCH3-15**  
for L = 1.5"  
**SCH3-30**  
for L = 3.0"

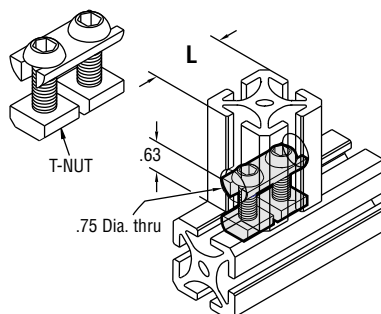

### Single End Butt Connector

Hardware Included.

**SCH4**

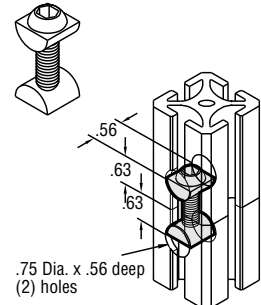

### Double End Butt Connector

Hardware Included.

**SCH4-15**  
for L = 1.5"  
**SCH4-30**  
for L = 3.0"

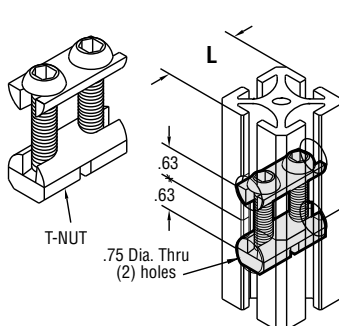

### Single Cross Connector

For use on SX1010L and SX1015L only. Hardware Included.

**SCH3-10**

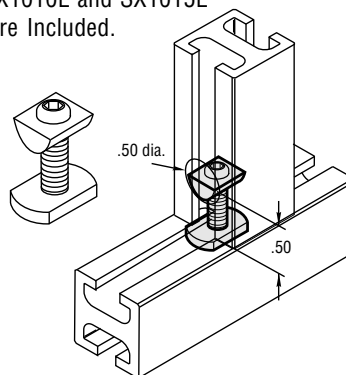

### Double Cross Connector

For use on SX1010L and SX1015L only. Hardware Included.

**SCH4-10**

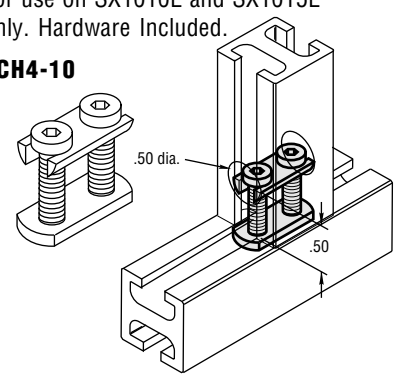

**Material:** Alloy Steel  
**Finish:** Zinc Plate

## 5/16 Inch Washers, Nuts and Fasteners — Standard & [Miniature]

### 5/16" Washers [1/4"]

Sold in 10 piece increments

**SCH6**  
**[SCH6M]**

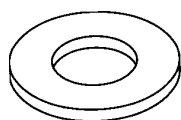

**Material:** Hardened Steel  
**Finish:** Black Oxide Coat

### Serrated Belleville

Sold in 10 piece increments

**SCH6-1**

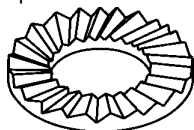

**Material:** Steel  
**Finish:** Black Oxide Coat

### 5/16" - 18 Hex Nuts [1/4"-20]

Sold in 10 piece increments

**SCH6-2**  
**[SCH6M-2]**

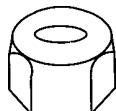

**Material:** Steel  
**Finish:** Zinc Plate

### Push Lock Fastener

Sold in 10 piece increments

**Material:** Gray Plastic

**SCH5**  
**[SCH5M]**

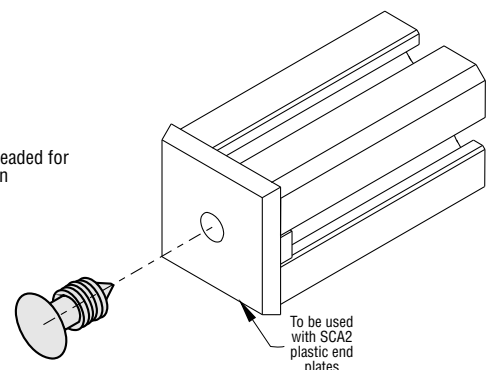
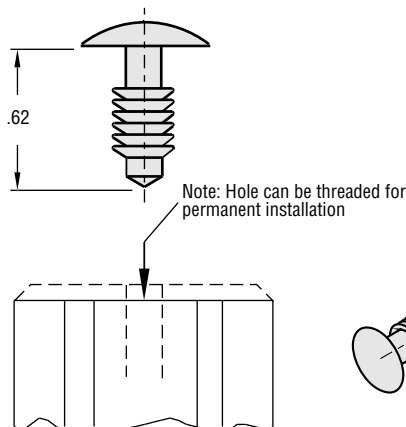

# FASTENING HARDWARE

## Fasteners / T-Slot Bolts and Screws — Standard & [Miniature]

### Drop In And Turn 5/16" - 18 T-Bolts

Loads into extrusion from side.

**Material:** Alloy Steel  
**Finish:** Zinc Plate

L (Inch)	Part Number
.75	SCH6-07
1.00	SCH6-10

SCH6- □ □

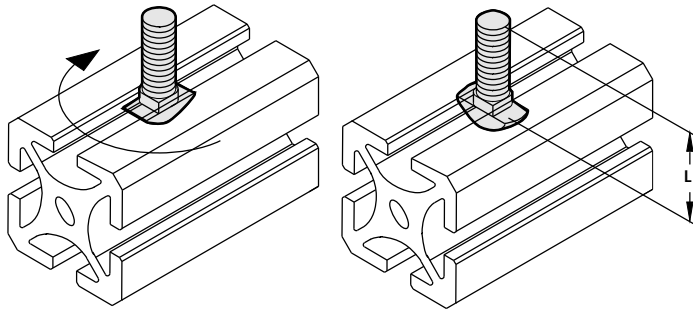

### Economy 5/16" - 18 T-Bolts

Loads from end only. Sold in increments of 10 pieces.

**Material:** Alloy Steel  
**Finish:** Zinc Plate

L (Inch)	Part Number
.75	SCH7-07
1.00	SCH7-10
1.25	SCH7-12
1.50	SCH7-15
2.00	SCH7-20

SCH7- □ □

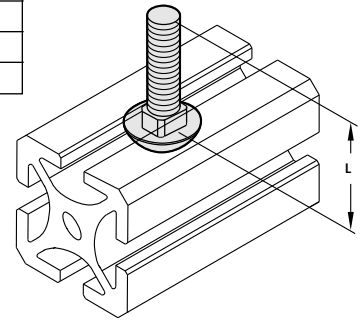

### 5/16" - 18 Standard Socket Head Cup Screws [1/4"-20]

Sold in increments of 10 pieces.

**Material:** Alloy Steel  
**Finish:** Black Oxide

#### Standard Screws

L (Inch)	Part Number
.50	SCH8-05
.63	SCH8-06
.75	SCH8-07
1.0	SCH8-10
1.25	SCH8-12
1.5	SCH8-15
2.0	SCH8-20

SCH8- □ □

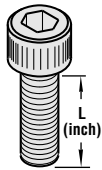

#### Miniature Screws

L (Inch)	Part Number
.44	SCH8M-04
.50	SCH8M-05
.63	SCH8M-06
.75	SCH8M-07
1.0	SCH8M-10
1.25	SCH8M-12

SCH8M- □ □

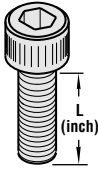

### 5/16" - 18 Standard Button Head Cup Screws [1/4"-20]

Sold in increments of 10 pieces.

**Material:** Alloy Steel  
**Finish:** Black Oxide

#### Standard Screws

L (Inch)	Part Number
.50	SCH9-05
.63	SCH9-06
.75	SCH9-07
1.0	SCH9-10
1.25	SCH9-12
1.5	SCH9-15

SCH9- □ □

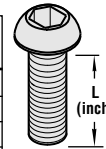

#### Miniature Screws

L (Inch)	Part Number
.44	SCH9M-04
.50	SCH9M-05
.63	SCH9M-06
.75	SCH9M-07
1.0	SCH9M-10
1.25	SCH9M-12

SCH9M- □ □

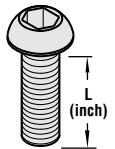

# ACCESSORIES

## Door Tracks, Plastic End Plates, Gasket and Covers — Standard & [Miniature]

### Plastic Upper Door Slide Track

Sold in 6 foot lengths. **Color:** Gray

#### SCA1-U

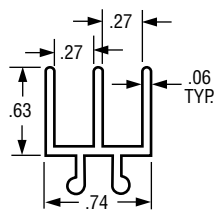

### Plastic Lower Door Slide Track

Sold in 6 foot lengths. **Color:** Gray

#### SCA1-L

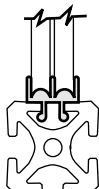
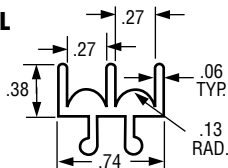

### Plastic End Plates

Use with part number SCH5. **Color:** Gray

#### SCA2- □ □ □ □

##### SCA2-1515

For extrusion SX1515 [SCA2M-1010] for SX1010M



##### SCA2-1530

For extrusion SX1530 [SCA2M-1020] for SX1020M

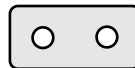

##### SCA2-3030

For extrusion SX3030 [SCA2M-2020] for SX2020M

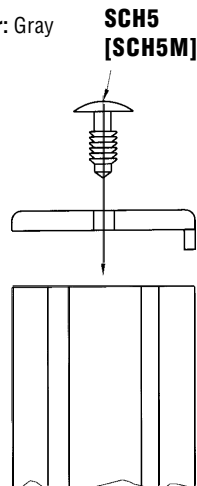
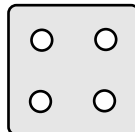

### Plastic T-Slot Cover and Panel Gasket

Sold in 6 foot lengths.

#### SCA3 [SCA3M] — Grey

#### SCA3Y [SCA3YM] — Yellow

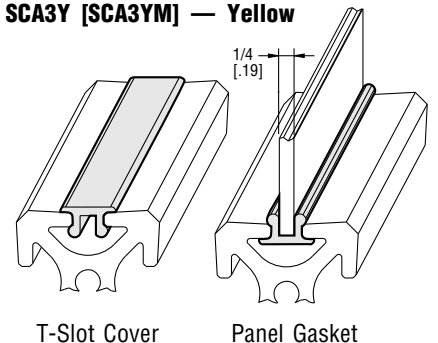

T-Slot Cover

Panel Gasket

# ACCESSORIES

## Leveling, Anchor and Caster Plates. Adjustable Legs and Casters — Standard & [Miniature]

### Leveling Plate

Requires SCH8-10(2) [SCH8M-10].  
Use with SCE4 [SCE4M] adjustable leg.

**Material:** Aluminum  
**Finish:** Clear Anodize

#### SCE1 [SCE1M]

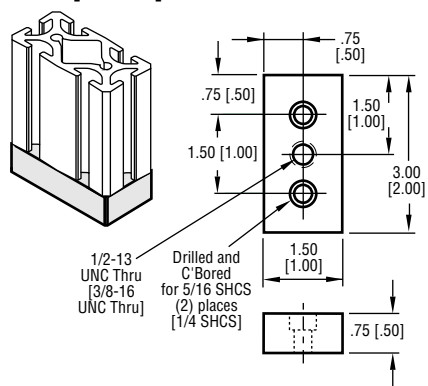

### Leveling Plate

Requires SCH8-10(4) [SCH8M-10].  
Use with SCE4 [SCE4] adjustable leg.

**Material:** Aluminum  
**Finish:** Clear Anodize

#### SCE2 [SCE2M]

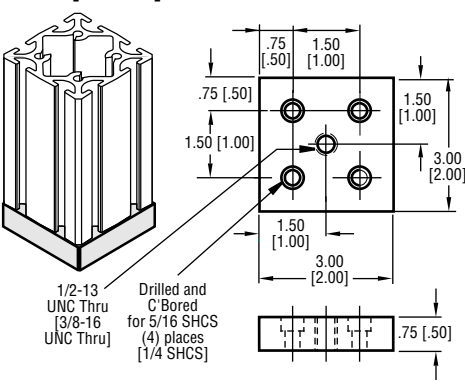

### Leveling Anchor Plate

Requires SCH8-10(4) [SCH8M-10].  
Use with SCE4 [SCE4M] adjustable leg.

**Material:** Aluminum  
**Finish:** Clear Anodize

#### SCE2-A [SCE2M-A]

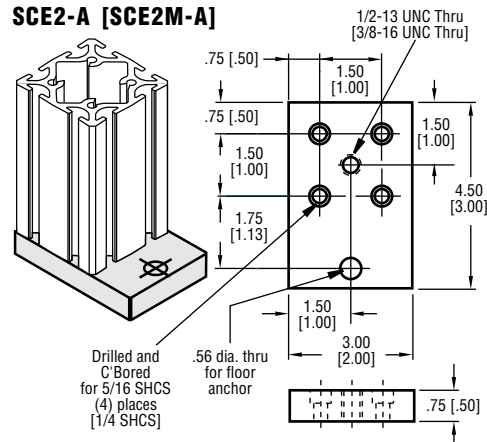

### Leveling Anchor Plate

Requires SCH8-10(2) [SCH8M-10].  
Use with SCE4 [SCE4M] adjustable leg.

**Material:** Aluminum  
**Finish:** Clear Anodize

#### SCE1-A [SCE1M-A]

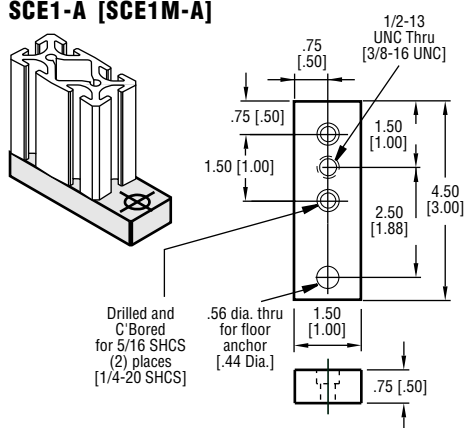

### 3" and 4" Caster Plate

Requires SCH8-10(4).  
Use with SCE5 caster.

**Material:** Aluminum  
**Finish:** Clear Anodize

#### SCE3 [SCE3M]

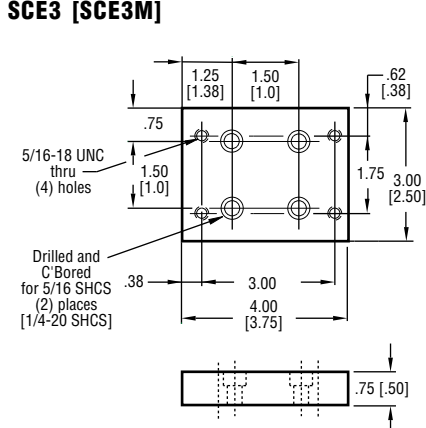

### Adjustable Leg

1,800 pound maximum capacity.

**Material:** Steel  
**Finish:** Bronze Coating

#### SCE4 [SCE4M]

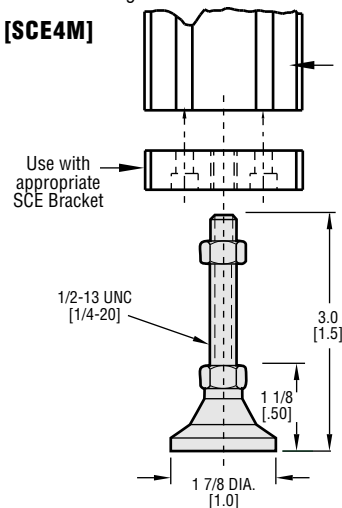

### 3" and 4" Caster

Use with SCE3 caster plate (see above).

#### SCE5-

Description	Part Number
3" caster-swivel	SCE5-3S
3" caster-fixed	SCE5-3F
3" caster-swivel / brake	SCE5-3B
4" caster-swivel	SCE5-4S
4" caster-fixed	SCE5-4F
4" caster-swivel / brake	SCE5-4B

### 3" Caster

SCE5-3  (SCE5-3B shown)  
90 pound maximum capacity.

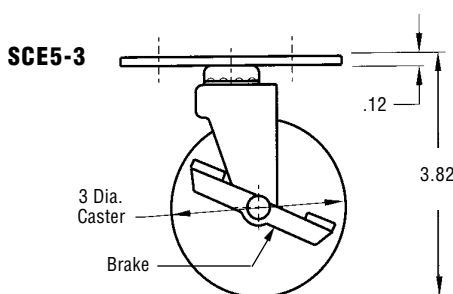

### 4" Caster

SCE5-4  (SCE5-4F shown)  
130 pound maximum capacity.

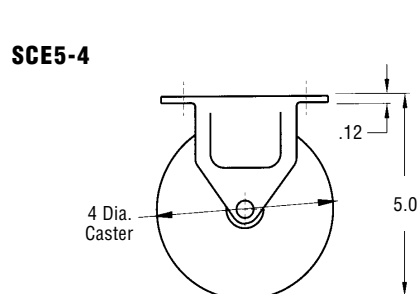

# ACCESSORIES

Standard & [Miniature]

## T-Slot Roller

Ideal for guided linear applications, mount to extrusion end or T-Slot; rolls in the mating T-Slot. Hardware included.

**Material:** Delrin with Bronze Bearing

**Color:** White

### SCA6 [SCA6M]

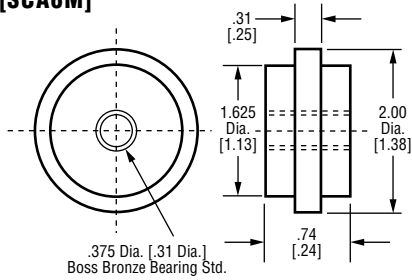

## Plastic Handle

**Color:** Black.  
Hardware included.

### SCA9-3 [SCA9M-3]

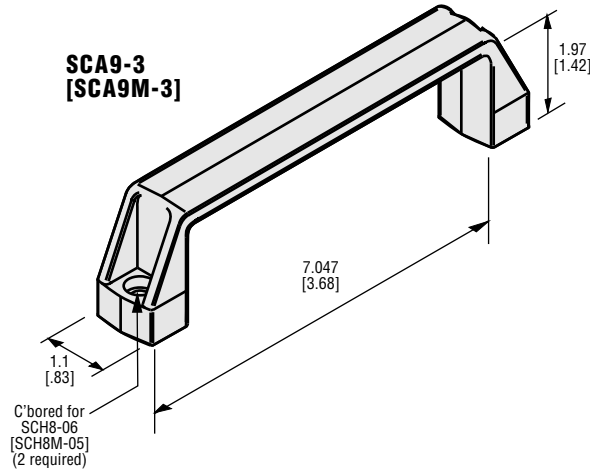

## Aluminium Handle

**Finish:** Clear Anodize.  
Hardware included.

### SCA9-2

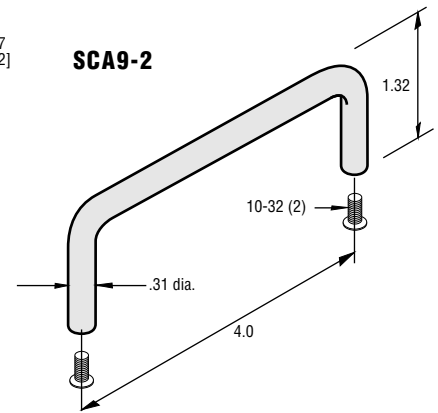

## Plastic Hinge

Hardware included.  
**Color:** Black.

### SCA7-1

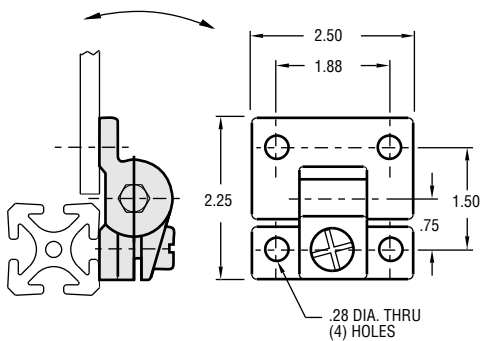

## Aluminium Hinge

**Finish:** Clear Anodize.

### SCA7-2

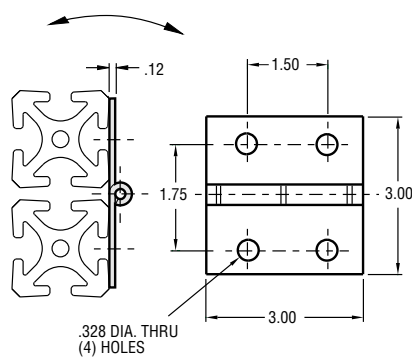

## Magnetic Door Latch Assembly

Hardware included.  
**Material:** Plastic with metal magnet  
**Color:** Brown

### SCA8

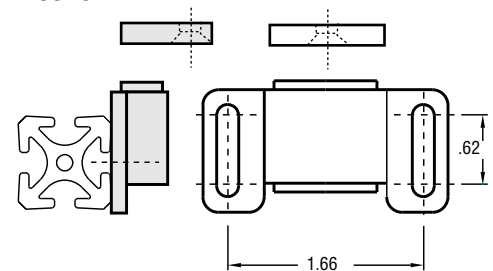

# EXTRUSION END FINISHING

## Ordering Information

When ordering aluminum extrusions specify quantity, part number with length. Example: **SX1515-144** for standard 144" lengths.

You may also order extrusions cut to your desired length with a nominal cutting charge. Example: **SX1515-72.25** for length of 72 1/4".

**Length Tolerance:** Standard saw cut lengths  $\pm 1/32$   
 Precision milled cut lengths  $\pm .005$ . If precision milled cut desired, add P to end of part number  
 Example: **SX1515-24P** for length of 24"  $\pm .005$

Lengths shorter than 106" can be shipped by UPS. Lengths over 106" will be shipped by commercial carrier with longer delivery times and increased costs.

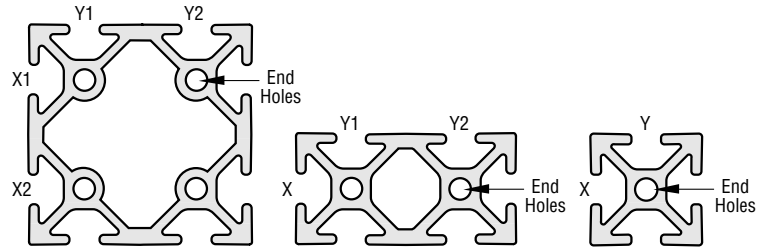

**Predrilled access, connector and tapped holes available.**  
 Call factory for information and quotations.

When ordering predrilled access holes, connector holes and tapped end holes, specify T-Slot location and at which end holes are to be drilled.

# DO IT YOURSELF DETAILS — STANDARD

## Mounting Hole Positions For Cross and End Fasteners

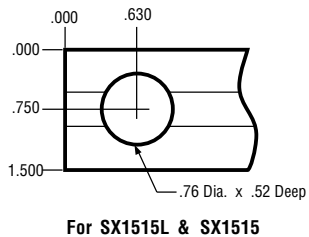
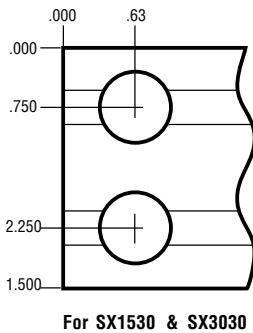
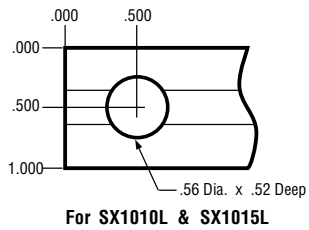

## Access Holes For Corner Brackets

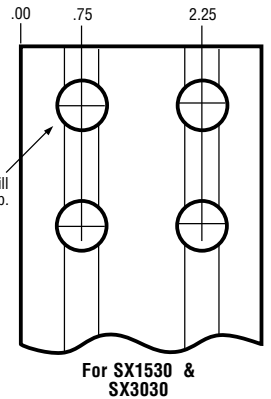
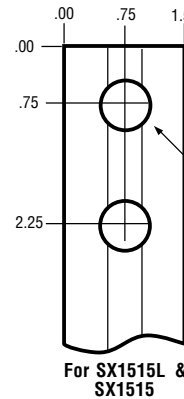
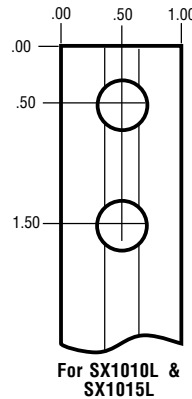

## 45° Supports

